

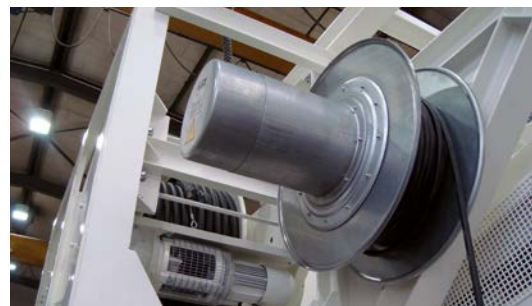

VAHLE

Spring Operated Cable Reels

SYSTEMS IN MOTION



Spring Operated Cable Reels

Content	Page
Spring operated cable reels	3
Reel selection charts	5
Typical applications	6
Model explanation	7
Reel selection charts	8

Application

Our spring operated cable reels serve the industry for reliable electrification of equipment in motion; for automatic winding of flexible power- and control-cables.

Application areas

Portal- and Gantry Cranes, Dockside-, Ship- and Construction Cranes, Grabs and Magnets, Electric Hoists and other material handling -lifting -stacking and -storing equipment. They fully meet VDE and UVV safety requirements.

Special applications

- VAHLE Reels on board ships or in the tropics.
- VAHLE Reels in aggressive environments (galvanizing plants, pickling lines, sewage treatment systems).
- VAHLE Reels in explosionproof versions (slipringless).
- VAHLE Reels for Control-, Signal- and Highfrequency-Transmission.
- VAHLE Reels for Air, Liquids and Gases (Hose Reels).
- VAHLE Reels for handling steel ropes in travel distance-tracking systems and for grab stability on heavy cranes (Tag Line Reels).
- VAHLE Reels for Curves and for Endless Monorails with special swivel base.
- VAHLE Reels of the Ratchet Type with a lock mechanism for multi level machine tools and for push-button pendants.
- VAHLE Reels for Flatform Cable (especially in the palette stacking and machine tool industry).
- VAHLE Reels in Monospiral Version.

Vahle welcomes your inquiry on your particular application.

Content	Page
Cable reels (with fixing flange)	25
Cable reels (with console)	27
Accessories	28
Spare parts.....	34
Questionnaire.....	36
Notes.....	38

Electrical Properties of Sliprings

Standard sliprings are rated for 500 Volt AC and 600 Volt DC, Control Rings in block system for 230 Volts. Collector Ring Ampere capacities are for 100% nominal rating.

Protection Code

Slipring enclosures are designed to IP 55. Higher grade protection – available upon request.

Drive System

The Reel Drive is achieved via helical springs of high quality spring steel. Depending on the duty and type of service they will last about 120.000 working cycles.

Cable Payout

is normally following the technical information on pages 25 and 27 of this catalog. Other requirements can be fulfilled; add suffix A in the type designation for opposite hand rotation. (See model code on page 7).

Limit Switch Assemblies

for switching off travel and hoist motors with one or two safety windings on the reel are optional.

Accident Prevention

All moveable parts of the drive system, e.g. chaindrive are covered in accordance with the Accident Prevention Code. Therefore, the cable reels can be installed in work areas as well as traffic areas. Additional protective devices, such as a cover for the revolving reel body itself, are to be furnished and fitted at site.

Corrosion Protection

The all-steel construction of the VLF 155 to VLF 530 reel series is galvanized. All other reels come with one primer coat and one finishing paint of epoxy-resin RAL 7031 blue-grey varnish.

Installation Information

Installation instructions and operation manuals for commissioning advice and assistance are attached to each reel shipment.

Reel Capability

max. speed of travel or lift application: $v = 60 \text{ m/min.}$
max. travel acceleration: $a = 0,2 \text{ m/sec}^2$
max. lift acceleration: $a = 0,2 \text{ m/sec}^2$

Cable length

Reels are designed to handle a certain type and length of cable in a specific manner. Never use reels for more cable than outlined in the selection charts. Two safety windings are included on the reeling body.

Total cable length

The total cable length required results from maximum pay-out length plus reel installation height plus two safety windings plus free end length for connection.

Safety Advice

According to EEC-regulation 89/392/EWG rotating parts such as reel compartments must be protected against accidents.

Guarantee

We provide guarantee according to the general conditions of delivery for products and services of the electrical industry. The reel springs are as a wear part excluded from this guarantee.

Reeling cables

Reeling cables which correspond to the mechanical requirements should be used.

Factors in selecting cable for reel use, considering motor currents, required wire sizes and allowable voltage drop.

$$A = \frac{1,73 \cdot L \cdot I_G \cdot \cos\varphi}{\Delta U \cdot x} \text{ (mm}^2\text{)}$$

Legend to Formula:

A = Required Wire Size
(Conductor Cross Section in sq. mm)
L = Total Cable Length (m)
I_G = Total Ampere Load (Amps)
cos φ = Power Factor = approx. 0,8
x = Conductor Conductivity (Copper = 56)
Δ U = Allowable Voltage Drop (Volts)

Cable selection and determining wire size ampacity, considering permissible temperature rise

The reel selection charts are based on the cable data as per table No. 1, indicating continuous ampacity for 3-conductor open air installation with an ambient temperature of 30 °C. Use derating table No. 3 for other ambient temperature. The continuous ampacities as per table No. 1 are only applicable to a limited extend for cables under reeling operation. The derating factors for multilayer service are shown in table No. 4. They are valid for permanently and fully spooled cables.

However, as many applications in practice do not have the cable fully spooled all the time, it is recommended to use an intermediate factor only. For monospiral winding refer to the same continuous ampacities than for one-layer operation. The continuous ampacities as per table 1 are suitable also for 4-core cables. Also 5-core arrangements are permissible, if one core is used as ground. If necessary consider the cable accumulation for dimensioning of the cables according to VDE 0100 §41 regulation.

The following derating factors (table No. 5) are nearly suitable for multi-core cables, depending on the quantity of cores. The following derating factors (table No. 2) are valid for intermittent service in relation to the continuous ampacities for permanent load as per table No. 1.

Reel selection tables

for arrangement samples - random wrap, horizontal or vertical cable payout or steeply rising -

Table 1: Continuous cable ampacity (100% CD) for open air installation (without consideration of the voltage drop)

Wire size (mm ²)	Ampere Capacity (A)
	30° C
1,5	23
2,5	30
4	41
6	53
10	74
16	99
25	131
35	162
50	202

Table 2: Multiplier for intermittent service (according to manufacturers' instructions)

Wire size (mm ²)	at intermittent duty cycle of (according to manufacturers' instructions)			
	60%	40%	25%	15%
1,5	1,00	1,00	1,00	1,00
2,5	1,00	1,00	1,04	1,07
4	1,00	1,03	1,05	1,19
6	1,00	1,04	1,13	1,27
10	1,03	1,09	1,21	1,44
16	1,07	1,16	1,34	1,62
25	1,10	1,23	1,46	1,79
35	1,13	1,28	1,53	1,90
50	1,16	1,34	1,62	2,03

Table 3: Derating for other ambient temperature for open air installation

Ambient temp. °C	Conversion factor									
	25	30	35	40	45	50	55	60	65	70
Conversion factor f_r	1,05	1,00	0,95	0,89	0,84	0,77	0,71	0,63	0,55	0,45

Table 4: Derating for multilayer service

No. of Cond. in service	1	2	3	4
Multiplier	0,80	0,61	0,49	0,42

Table 5: Derating for multiconductor service

No. of Cond. in service	5	7	10	14	19	24	40
Multiplier	0,75	0,65	0,55	0,50	0,45	0,40	0,35

Typical Applications

Reel on moving equipment

Cable on the ground or in a continuous tray
Horizontal Cable payout in one or two directions

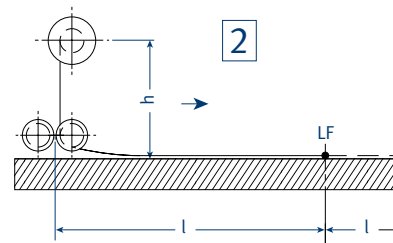
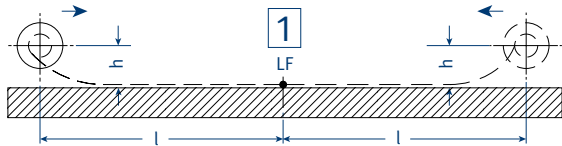

Reel on moving equipment

Cable on supports ($l_1 = 1\text{m}$), or rather rolls or rounded smooth supports ($l_1 = 1\text{ to }3\text{ m}$)
Horizontal Cable payout in one or two directions

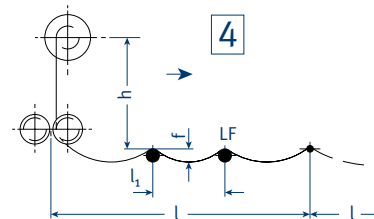
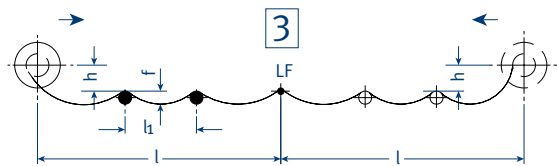

Reel stationary

(Cable fixpoint at moving equipment), horizontal cable payout in one or two directions on rolls or smooth supports ($l_1 = 3\text{m}$)

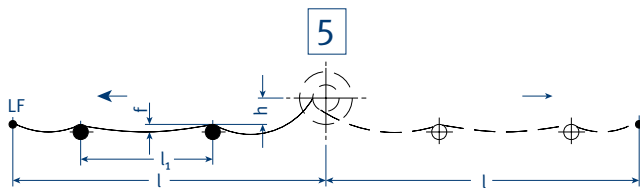

Reel on moving equipment (6) or Reel stationary (7) - (Cable fixpoint at moving equipment)

Free horizontal cable payout in one or two directions. For payout in one travel direction: „f“ is determining the loop depth if the suspended cable length „L“ is larger than „l“.

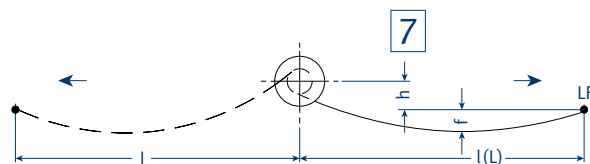
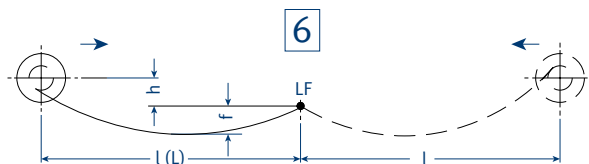

Legend to Drawings: (Examples 1-7)

l = max. operational length of cable (m)
(with cable payout in two travel directions = half travel length)

L = max. operational length [m] between reel and cable fixpoint

h = Installation height = distance from cable tray or cable fixpoint to reel center [m]

LF = Cable fixpoint

f = max. cable loop depth [m], relating to cable fixpoint "LF"

l_1 = Rolls or support distance [m]

Lifting operation

Cable payout vertical or steeply sloping (8)

Cable payout vertical or steeply rising (9)

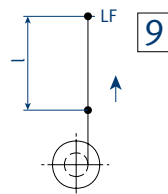
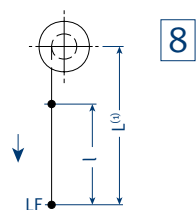

Legend to Drawings (Examples 8 and 9)

l = operational length of cable

L = max. sloping cable length (m). Also consider additional weight (e.g. control switch)

LF = Cable fixpoint

Note

For applications 2, 4, 5 and reels beyond the listed capacities please fill in the questionnaire on page 36 and consult your local agent or our factory.

1) The sloping cable length is relevant for cable reel selection. Also consider additional weight (control switch).

Model Explanation

Reel type

VLF	220	-	2	-	951H	-	4	-	26
VLF	530	-	2	-	985	-	4	-	150
VLKG	700	-	6	-	915	-	4	-	220 - A

Reel Series

Drum Dia.

No. of Springs

Spring Series

No. of Poles incl. Ground

Amps

Suffix for opposite rotation

Selecting a VAHLE Cable Reel

To select the right Vahle Reel from the Reel Selection Charts you must know the application (see page 6), the length and the type of cable (wire size, number of conductors, outside diameter, weight per meter).

Legend to Selection table:

l = max. operational length of cable

L = max. sloping cable length (m). („L“ can coincide with max. operational reeling length „l“).

h = max. mounting height = distance from cable tray or cable fix point to center of reel (m).

Measure „h“ might be exceeded if ground clearance is sufficient (e.g. for cable payout in one travel direction). Provide guide- or tension relief devices for cable payout in two travel directions or passing over the cable fix point.

LZ = No. of layers on reel (partly required for determination of cable cross section).

nv = required initial spring tension turns

n = max. operational and permissible turns for max. cable length „l“.

Z = max. reel torque for cable payout (N)

f = max. cable loop depth relating to cable fixpoint "LF" (m)

Note

Initial spring tension nv can be increased when reducing the max. cable length to be handled. However, never exceed the total permissible turns nv+n.

Reel selection table

for application 1, 3 and 9, random wrap, horizontal/vertical cable payout or steeply rising

Trommelflex Pur - HF 4 x 1,5 mm², Ø 11,2 mm, 0,155 kg/m

	l(m)	h(m)	LZ~	Reel type	weight (kg)	nv(U)	n(U)	Z(N)	Order No.
•	7	0,5	1,7	VLF155-1-908-4-26	3,1	2	13	40	902 010
•	12	0,5	2,0	VLF180-1-931-4-26	9,0	2	19	60	902 020
•	27	0,5	4,0	VLF180-2-931H4-26	11,0	4	38	60	902 022
•	28	1,0	5,0	VLF220-2-951H4-26	15,5	4	36	100	902 102
	44	1,0	3,9	VLF222-3-951H4-26	23,1	6	54	100	901 514
•	47	1,0	3,0	VLF300-2-952H4-26	28,0	4	45	100	902 291
	72	1,0	4,0	VLF301-3-952H4-26	34,2	6	69	100	901 515
	83	1,5	3,0	VLF420-2-953H4-36	56,0	4	58	120	902 401

Trommelflex Pur - HF 5 x 1,5 mm², Ø 11,8 mm, 0,178 kg/m

	l(m)	h(m)	LZ~	Reel type	weight (kg)	nv(U)	n(U)	Z(N)	Order No.
•	7	0,5	1,7	VLF155-1-908-5-26	3,5	2	13	40	902 016
•	12	0,5	2,0	VLF180-1-931-5-26	9,0	2	19	60	902 040
•	20	0,5	4,0	VLF180-2-931H5-26	11,0	4	37	60	902 042
•	26	1,0	3,0	VLF220-2-951H5-26	19,0	4	33	100	902 132
	39	1,0	4,0	VLF222-3-951H5-26	22,0	6	49	100	901 521
•	47	1,0	3,0	VLF300-2-952H5-26	28,0	4	45	100	902 322
	73	1,0	4,0	VLF301-3-952H5-26	34,2	6	69	100	901 376
	83	1,5	2,9	VLF420-2-953H5-36	56,0	4	58	120	902 441

Trommelflex Pur - HF 7 x 1,5 mm², Ø 13,5 mm, 0,218 kg/m

	l(m)	h(m)	LZ~	Reel type	weight (kg)	nv(U)	n(U)	Z(N)	Order No.
•	7	0,5	1,9	VLF155-1-908-7-26	3,5	2	13	40	902 008
•	10	0,5	3,0	VLF180-1-931-7-26	10,5	2	16	60	902 043
•	12	1,0	3,0	VLF220-1-951-7-26	19,5	2	16,5	100	902 160
•	20	1,0	3,0	VLF220-2-951H7-26	21,5	4	25	100	902 116
•	26	1,0	4,0	VLF221-2-951H7-26	22,8	2	33	100	902 282
	41	1,0	5,0	VLF222-3-951H7-26	23,1	6	49	100	901 516
•	49	1,0	3,5	VLF300-2-952H7-26	28,0	4	45	100	902 352
	73	1,0	4,0	VLF301-3-952H7-26	34,2	6	67	100	901 517
	80	1,5	4,0	VLF420-2-953H7-36	57,0	4	57	120	902 481

• The spring reelers are pre-assembled and available in two weeks ex works.

Trommelflex Pur - HF 12 x 1,5 mm², Ø 17,0 mm, 0,363 kg/m

	l(m)	h(m)	LZ~	Reel type	weight (kg)	nv(U)	n(U)	Z(N)	Order No.
•	7	0,5	2,0	VLF180-1-931-12-26	10,5	2	12	60	902 058
•	12	1,0	3,0	VLF220-1-951-12-26	19,5	2	16,5	100	902 183
•	22	1,0	4,0	VLF220-2-951H12-26	22,5	2	30	100	901 364
•	29	1,0	4,0	VLF221-2-951H12-26	23,5	4	33	100	902 283
	32	1,0	4,0	VLF222-3-951H12-26	26,0	6	38	100	901 518
•	50	1,0	4,0	VLF300-2-952H12-26	30,0	4	45	100	902 372
	56	1,5	4,0	VLF301-3-972H12-26	44,0	6	35	170	901 519
	71	1,5	4,0	VLF420-2-983H12-36	57,0	4	49	120	902 504
	79	1,5	4,0	VLF420-2-953H12-36	59,0	4	54	120	902 502
	85	1,5	5,0	VLF421-2-953H12-36	63,0	4	57	120	902 570
	106	1,5	3,5	VLK530-4-924-12-36	128,0	5	57	160	901 520

Trommelflex Pur - HF 18 x 1,5 mm², Ø 18,1 mm, 0,459 kg/m

	l(m)	h(m)	LZ~	Reel type	weight (kg)	nv(U)	n(U)	Z(N)	Order No.
•	8	1,0	2,0	VLF220-1-951-18-26	20,5	2	16,5	100	902 115
	11	1,0	2,5	VLF220-2-951-18-36	22,0	2	13	200	902 193
•	18	1,0	3,0	VLF221-2-951H18-26	25,0	4	22	100	902 281
•	23	1,0	3,0	VLF300-2-952-18-26	31,0	4	22,5	210	902 377
•	29	1,5	3,0	VLF300-2-972H18-26	38,0	4	28	180	901 435
	33	1,5	3,0	VLF420-1-983-18-36	55,0	2	24	120	902 506
•	40	1,5	4,0	VLF420-1-953-18-36	56,0	2	29	120	901 436
•	73	1,5	4,0	VLF420-2-983H18-36	58,0	4	49	120	902 509
	87	1,5	5,0	VLF421-2-953H18-36	61,0	4	57	120	901 522

Trommelflex Pur - HF 24 x 1,5 mm², Ø 20,9 mm, 0,590 kg/m

	l(m)	h(m)	LZ~	Reel type	weight (kg)	nv(U)	n(U)	Z(N)	Order No.
•	14	1,0	2,0	VLF300-1-952-24-36	29,0	2	16	100	902 378
	24	1,0	3,0	VLF300-2-952-24-36	31,0	2	22	210	902 380
	35	1,5	3,0	VLF420-2-983-24-36	59,0	2	24	240	902 521
•	41	1,5	3,0	VLF420-2-953-24-36	61,0	2	28	240	902 520
	45	1,5	3,1	VLF421-2-953-24-36	68,0	2	29	240	901 523
	76	1,5	3,3	VLF530-2-986H24-36	117,0	4	40	245	903 804
	89	1,5	3,8	VKLG530-6-924-24-36	152,0	4	46	305	901 524

• The spring reelers are pre-assembled and available in two weeks ex works.

Reel selection table

for application 1, 3 and 9, random wrap, horizontal/vertical cable payout or steeply rising

Trommelflex Pur - HF 30 x 1,5 mm², Ø 24,0 mm, 0,720 kg/m

	l(m)	h(m)	LZ~	Reel type	weight (kg)	nv(U)	n(U)	Z(N)	Order No.
•	12	1,0	2,0	VLF300-1-952-30-36	29,5	2	12	100	902 390
•	20	1,0	2,0	VLF300-2-952-30-36	31,0	2	19	210	900 316
	36	1,5	3,0	VLF420-2-983-30-36	60,0	2	24	240	901 115
•	38	1,5	3,0	VLF420-2-953-30-36	62,0	2	25	240	901 437
	46	1,5	3,4	VLF421-2-953-30-36	68,0	2	29	240	901 526
	78	1,5	3,6	VLF530-2-986H30-36	118,0	4	40	245	901 527
	91	1,5	4,0	VLKG530-6-924-30-36	152,0	4	46	305	901 528

Trommelflex Pur - HF 4 x 2,5 mm², Ø 12,3 mm, 0,208 kg/m

	l(m)	h(m)	LZ~	Reel type	weight (kg)	nv(U)	n(U)	Z(N)	Order No.
•	7	0,5	2,0	VLF155-1-908-4-26	4,0	2	11,5	40	902 010
•	10	0,5	2,0	VLF180-1-931-4-26	9,0	2	18	60	902 020
•	18	0,5	3,0	VLF180-2-931H4-26	10,0	4	28	60	902 022
•	26	1,0	4,0	VLF220-2-951H4-26	19,5	4	34	100	902 102
	42	1,0	4,0	VLF222-3-951H4-26	23,0	6	50	100	901 514
•	46	1,0	4,0	VLF300-2-952H4-26	25,0	4	45	100	902 291
	68	1,0	4,0	VLF301-3-952H4-26	34,0	6	67	100	901 515
	83	1,5	4,0	VLF420-2-953H4-36	56,0	4	58	120	902 401
	88	1,5	3,0	VLF530-2-985H4-36	110,0	4	50	130	903 780
	102	1,5	2,6	VLK530-3-924-4-36	116,0	5	58	120	901 529

Trommelflex Pur - HF 5 x 2,5 mm², Ø 13,0 mm, 0,230 kg/m

	l(m)	h(m)	LZ~	Reel type	weight (kg)	nv(U)	n(U)	Z(N)	Order No.
•	7	0,5	1,0	VLF155-1-908-5-26	6,0	2	12	40	902 016
•	10	0,5	2,0	VLF180-1-931-5-26	10,0	2	18	60	902 040
•	18	0,5	3,0	VLF180-2-931H5-26	11,0	4	28	60	902 042
•	26	1,0	2,9	VLF220-2-951H5-26	16,0	4	25	100	902 132
	40	1,0	3,5	VLF220-3-951H5-26	18,5	6	33	100	901 530
•	46	1,0	4,0	VLF300-2-952H5-26	25,5	4	45	100	902 322
	69	1,0	4,0	VLF300-3-952H5-26	28,0	6	67,5	100	902 329
	80	1,5	3,5	VLF420-2-953H5-36	56,0	4	57	120	902 441
	103	1,5	2,6	VLK530-3-924-5-36	116,0	6	58	120	901 844

• The spring reelers are pre-assembled and available in two weeks ex works.

Trommelflex Pur - HF 7 x 2,5 mm², Ø 14,7 mm, 0,315 kg/m

	l(m)	h(m)	LZ~	Reel type	weight (kg)	nv(U)	n(U)	Z(N)	Order No.
•	10	0,5	2,0	VLF180-1-931-7-26	9,0	2	18	60	902 043
•	12	0,5	3,0	VLF220-1-951-7-26	15,5	2	16,5	100	902 160
•	17	1,0	3,0	VLF220-2-951H7-26	19,0	4	33	100	902 116
•	26	1,0	4,0	VLF221-2-951H7-26	20,0	4	33	100	902 282
	41	1,0	5,0	VLF222-3-951H7-26	21,0	6	49	100	901 516
•	47	1,0	4,0	VLF300-2-952H7-26	29,0	4	45	100	902 352
	71	1,0	4,0	VLF301-3-952H7-26	35,0	6	67	100	901 517
	81	1,5	4,0	VLF420-2-953H7-36	55,0	4	57	120	902 481
	104	1,5	2,9	VLK530-4-924-7-36	129,0	5	58	160	901 531

Trommelflex Pur - HF 12 x 2,5 mm², Ø 20,5 mm, 0,485 kg/m

	l(m)	h(m)	LZ~	Reel type	weight (kg)	nv(U)	n(U)	Z(N)	Order No.
•	10	1,0	3,0	VLF220-1-951-12-26	19,5	2	16,5	100	902 183
•	16	1,0	3,0	VLF221-2-951H12-26	23,5	4	33	100	902 283
•	25	1,0	2,7	VLF300-2-952-12-26	30,0	2	22	210	902 371
	29	1,0	4,0	VLF301-3-972H12-26	34,0	6	52	100	901 519
	34	1,5	3,0	VLF420-1-983-12-36	53,0	2	24	120	902 512
•	41	1,5	2,8	VLF420-1-953-12-36	55,0	2	28	120	902 500
	83	1,5	5,0	VLF421-2-953H12-36	60,0	4	57	120	902 570
	85	1,5	5,0	VLF530-2-985H12-36	66,0	4	57	200	903 819
	107	1,5	4,0	VKLG530-5-924-12-36	142,0	5	56	200	901 532

Trommelflex Pur - HF 18 x 2,5 mm², Ø 20,6 mm, 0,679 kg/m

	l(m)	h(m)	LZ~	Reel type	weight (kg)	nv(U)	n(U)	Z(N)	Order No.
•	8	1,0	2,0	VLF220-1-951-18-26	20,5	2	16,5	100	902 115
•	15	1,0	3,0	VLF221-2-951H18-26	23,0	4	22	100	902 281
•	26	1,0	3,0	VLF300-2-952H18-26	32,0	4	32	100	901 428
	27	1,0	3,0	VLF300-2-972H18-26	36,0	4	35	170	901 435
•	34	1,5	3,0	VLF420-2-983-18-36	58,0	2	24	240	902 510
	45	1,5	3,0	VLF420-2-953H18-36	60,0	4	57	120	901 533
	69	1,5	3,0	VLF530-2-986H18-36	65,0	4	40	245	901 534
	87	1,5	3,4	VLK530-4-924-18-36	140,0	4	46	200	901 535
	104	1,5	4,0	VKLG530-5-924-18-36	150,0	5	54	200	901 536

• The spring reelers are pre-assembled and available in two weeks ex works.

Reel selection table

for application 1, 3 and 9, random wrap, horizontal/vertical cable payout or steeply rising

Trommelflex Pur - HF 24 x 2,5 mm², Ø 23,6 mm, 0,860 kg/m

	l(m)	h(m)	LZ~	Reel type	weight (kg)	nv(U)	n(U)	Z(N)	Order No.
•	12	1,0	2,0	VLF300-1-972-24-36	35,0	2	19	165	901 438
•	22	1,0	3,0	VLF300-2-972-24-36	35,0	2	19	330	902 294
	36	1,5	3,0	VLF421-2-983-24-36	63,0	2	24	240	901 537
	43	1,5	3,6	VLF421-2-953-24-36	70,0	2	29	240	901 523
	79	1,5	3,8	VLF530-2-986H24-36	133,0	4	40	245	903 804
	88	1,5	4,0	VKLG530-5-925-24-36	144,0	5	44	300	901 538

Trommelflex Pur - HF 30 x 2,5 mm², Ø 28,2 mm, 1,080 kg/m

	l(m)	h(m)	LZ~	Reel type	weight (kg)	nv(U)	n(U)	Z(N)	Order No.
•	8	1,5	1,0	VLF420-1-983-30-36	68,0	2	24	120	902 525
•	20	1,5	2,0	VLF420-2-983-30-36	68,0	2	24	240	901 115
	33	1,5	4,0	VLF421-2-953-30-36	75,0	2	28	240	901 526
	77	1,5	4,0	VLF530-2-986H30-36	135,5	4	38	245	901 527
	98	1,5	3,6	VKLG700-6-925-30-36	238,0	4	39	340	901 227

Trommelflex Pur - HF 4 x 4 mm², Ø 13,6 mm, 0,281 kg/m

	l(m)	h(m)	LZ~	Reel type	weight (kg)	nv(U)	n(U)	Z(N)	Order No.
•	10	0,5	2,0	VLF180-1-931-4-40	8,5	2	18	60	901 102
•	12	0,5	3,0	VLF220-1-951-4-40	18,0	2	25	100	902 110
	16	1,0	3,0	VLF220-2-951H4-40	20,0	4	33	100	902 114
•	26	1,0	4,0	VLF221-2-951H4-40	22,0	4	33	100	902 214
•	47	1,0	4,0	VLF300-2-952H4-40	31,0	4	45	100	902 302
	73	1,0	3,5	VLF301-3-952H4-40	37,0	6	67	100	901 402
	81	1,5	4,0	VLF420-2-953H4-42	55,0	4	58	120	902 411
	103	1,5	2,7	VLK530-4-924-4-42	156,0	5	58	160	901 539

Trommelflex Pur - HF 5 x 4 mm², Ø 14,5 mm, 0,318 kg/m

	l(m)	h(m)	LZ~	Reel type	weight (kg)	nv(U)	n(U)	Z(N)	Order No.
	4	0,5	1,0	VLF180-1-931-5-40	7,8	2	18	60	901 287
	9	0,5	2,0	VLF180-2-931-5-40	8,5	2	18	120	902 050
	12	0,5	3,0	VLF220-1-951-5-40	17,5	2	16	100	902 140
	26	1,0	4,0	VLF221-2-951H5-40	21,0	4	33	100	902 251
	41	1,0	5,0	VLF222-3-951H5-40	24,0	6	49	100	901 540
	50	1,0	3,9	VLF300-2-952H5-40	28,0	4	45	100	902 331
	70	1,0	4,0	VLF301-3-952H5-40	36,5	6	67	100	901 541
	81	1,5	4,0	VLF420-2-953H5-42	55,5	4	57	120	902 451
	104	1,5	3,0	VLK530-4-924-5-42	156,0	5	58	160	901 542

• The spring reelers are pre-assembled and available in two weeks ex works.

Trommelflex Pur - HF 4 x 6 mm², Ø 14,9 mm, 0,372 kg/m

	l(m)	h(m)	LZ~	Reel type	weight (kg)	nv(U)	n(U)	Z(N)	Order No.
•	12	1,0	3,0	VLF220-1-951-4-60	16,0	2	16	100	902 120
•	21	1,0	3,0	VLF220-2-951H4-60	18,0	4	33	100	902 107
•	26	1,0	4,0	VLF221-2-951H4-60	22,0	4	33	100	901 439
•	50	1,0	3,9	VLF300-2-952H4-60	31,0	4	45	100	902 312
	57	1,0	4,0	VLF301-3-952H4-60	37,0	6	55	100	901 543
•	69	1,5	4,0	VLF420-2-983H4-60	54,0	4	48	120	902 425
	82	1,5	4,0	VLF420-2-953H4-60	56,0	4	57	120	902 422
	105	1,5	3,1	VLK530-4-924-4-60	156,0	5	58	180	901 544

Trommelflex Pur - HF 5 x 6 mm², Ø 16,1 mm, 0,435 kg/m

	l(m)	h(m)	LZ~	Reel type	weight (kg)	nv(U)	n(U)	Z(N)	Order No.
	9	1,0	2,9	VLF220-1-951-5-60	19,1	2	16	100	902 150
	12	1,0	3,0	VLF221-1-951-5-60	20,0	2	16	100	901 545
	27	1,0	4,0	VLF221-2-951H5-60	20,5	4	33	100	901 546
	32	1,0	4,0	VLF222-3-951H5-60	24,0	6	48	100	901 547
	37	1,0	4,0	VLF300-2-972H5-60	30,0	4	35	170	902 326
	55	1,0	4,0	VLF301-3-972H5-60	36,0	6	52	170	901 548
	71	1,5	4,0	VLF420-2-983H5-60	55,0	4	49	120	902 465
	84	1,5	5,0	VLF420-2-953H5-60	57,0	4	57	120	902 462
	106	1,5	3,3	VLKG530-5-924-5-60	168,0	5	58	200	901 549

Trommelflex Pur - HF 4 x 10 mm², Ø 18,9 mm, 0,615 kg/m

	l(m)	h(m)	LZ~	Reel type	weight (kg)	nv(U)	n(U)	Z(N)	Order No.
•	7	1,0	2,0	VLF220-1-951-4-60	19,0	2	16	100	902 120
•	13	1,0	3,0	VLF220-2-951-4-60	21,0	2	16	200	902 123
•	20	1,0	3,0	VLF221-2-951H4-60	22,0	4	33	100	901 439
	17	1,0	2,0	VLF300-1-972-4-60	26,0	2	17	170	901 401
	23	1,0	3,0	VLF300-2-952-4-60	28,0	2	22	200	902 311
•	29	1,0	3,0	VLF300-2-972H4-60	30,0	4	34	170	901 309
	34	1,5	4,0	VLF420-2-983-4-60	55,0	2	23	240	902 424
•	40	1,5	3,0	VLF420-2-953-4-60	57,0	2	28	240	902 421
	45	1,5	3,0	VLF420-2-984H4-60	59,0	4	32	235	902 414
	68	1,5	3,0	VLF530-2-986H4-60	131,0	4	40	245	903 783
	85	1,5	4,0	VLK530-4-924-4-60	156,0	4	46	200	901 544
	110	1,5	3,9	VLKG530-5-924-4-60	168,0	5	58	200	901 550

• The spring reelers are pre-assembled and available in two weeks ex works.

Reel selection table

for application 1, 3 and 9, random wrap, horizontal/vertical cable payout or steeply rising

Trommelflex Pur - HF 4 x 16 mm², Ø 22,1 mm, 0,924 kg/m

	l(m)	h(m)	LZ~	Reel type	weight (kg)	nv(U)	n(U)	Z(N)	Order No.
•	14	1,0	2,0	VL300-1-952-4-125	25,0	2	15	100	901 443
•	20	1,0	3,0	VL300-2-952-4-125	28,0	2	22	200	901 122
•	25	1,0	2,0	VL420-2-983-4-150	58,0	2	24	240	902 430
	35	1,5	2,0	VL421-2-983-4-150	60,0	2	24	240	902 541
	42	1,5	4,0	VL421-2-953-4-150	62,0	2	28	240	902 540
	71	1,5	4,0	VL530-2-986H4-150	131,0	4	40	245	903 788
	90	1,5	3,9	VL530-4-924-4-150	156,0	4	46	200	901 551

Trommelflex Pur - HF 4 x 25 mm², Ø 25,5 mm, 1,222 kg/m

	l(m)	h(m)	LZ~	Reel type	weight (kg)	nv(U)	n(U)	Z(N)	Order No.
•	15	1,5	2,0	VL420-2-983-4-150	58,0	2	14	240	902 430
	20	1,5	2,0	VL420-1-984-4-150	58,0	2	16	230	901 552
	33	1,5	3,0	VL421-2-983-4-150	60,0	2	25	240	902 541
	42	1,5	2,6	VL530-2-985-4-150	112,0	2	25	260	903 784
	80	1,5	4,0	VL530-4-924-4-150	138,0	4	46	200	901 551
	117	1,5	4,0	VL700-6-924-4-150	240,0	4	46	230	901 553

Trommelflex Pur - HF 4 x 35 mm², Ø 30,0 mm, 1,780 kg/m

	l(m)	h(m)	LZ~	Reel type	weight (kg)	nv(U)	n(U)	Z(N)	Order No.
	8	1,5	1,0	VL420-1-983-4-150	55,0	2	8	120	901 554
	20	1,5	2,0	VL420-2-983-4-150	58,0	2	15	240	902 430
	31	1,5	2,0	VL530-1-986-4-150	111,0	2	19	245	901 555
	49	1,5	2,8	VL530-2-985-4-150	112,0	2	25	265	903 784
	100	1,5	3,7	VL700-4-925-4-150	188,0	4	39	230	903 190

- The spring reelers are pre-assembled and available in two weeks ex works.

Reel selection table

for the application samples 6 and 7, random wrap, horizontal cable payout

Trommelflex Pur - HF 4 x 1,5 mm², Ø 11,2 mm, 0,155 kg/m

	l(m)	h(m)	~f(m)	LZ~	Reel type	weight (kg)	nv(U)	n(U)	Z(N)	Order No.
	7	1,0	0,5	1,7	VLF155-1-908-4-26	3,1	2	13	40	902 010
	12	1,0	0,6	1,9	VLF180-1-931-4-26	9,0	2	19	60	902 020
	22	1,5	1,0	3,0	VLF220-2-951H4-26	19,0	4	31	100	902 102
	30	1,5	1,1	2,0	VLF300-2-972H4-26	52,0	12	30	165	902 293
	35	1,5	1,0	1,4	VLF420-2-983-4-36	56,0	2	25	240	901 595
	40	1,5	1,2	1,0	VLF530-2-985-4-36	110,0	3	24	260	901 592

Trommelflex Pur - HF 5 x 1,5 mm², Ø 11,8 mm, 0,178 kg/m

	l(m)	h(m)	~f(m)	LZ~	Reel type	weight (kg)	nv(U)	n(U)	Z(N)	Order No.
•	7	1,0	0,5	1,7	VLF155-1-908-5-26	3,1	2	13	40	902 016
	8	1,0	0,7	2,0	VLF155-2-908H5-26	3,7	10	15	40	902 015
•	12	0,5	0,6	2,1	VLF180-1-931-5-26	10,5	2	19	60	902 040
	16	0,5	0,3	2,4	VLF220-2-951-5-26	19,0	2	18	200	902 131
	28	1,5	1,1	2,0	VLF300-2-972H5-26	52,0	11	28	165	902 325
	34	1,5	1,0	1,4	VLF420-2-983-5-36	56,0	2	24	240	902 442
	37	1,5	1,2	1,0	VLF530-2-985-5-36	110,0	3	22	260	901 593

Trommelflex Pur - HF 7 x 1,5 mm², Ø 13,5 mm, 0,218 kg/m

	l(m)	h(m)	~f(m)	LZ~	Reel type	weight (kg)	nv(U)	n(U)	Z(N)	Order No.
•	7	0,5	0,5	1,8	VLF155-1-908-7-26	3,1	2	13	40	902 008
•	12	1,0	0,4	2,0	VLF220-1-951-7-26	18,0	3	16	100	902 160
•	22	1,0	1,0	1,8	VLF300-2-972H7-26	34,0	10	22	165	902 295
	35	1,5	2,0	1,6	VLF420-2-953-7-36	57,0	6	25	240	901 567
	43	1,5	2,0	1,2	VLF530-2-985-7-36	111,0	2	25	260	901 594

• The spring reelers are pre-assembled and available in two weeks ex works.

Reel selection table

for the application samples 6 and 7, random wrap, horizontal cable payout

Trommelflex Pur - HF 12 x 1,5 mm², Ø 17 mm, 0,363 kg/m

	l(m)	h(m)	~f(m)	LZ~	Reel type	weight (kg)	nv(U)	n(U)	Z(N)	Order No.
•	7	1,0	0,4	2,0	VLF180-1-931-12-26	10,0	10	12	60	902 058
•	20	1,5	0,9	2,0	VLF300-2-952-12-26	30,0	3	19	210	902 371
	28	2,0	1,5	1,6	VLF420-2-983-12-36	58,0	5	20	240	902 503
	34	1,5	1,1	1,3	VLF530-2-986-12-36	132,0	2	20	490	903 799
	40	2,0	1,7	1,8	VLKG530-5-925-12-36	150,0	15	23	430	901 557

Trommelflex Pur - HF 4 x 2,5 mm², Ø 12,3 mm, 0,208 kg/m

	l(m)	h(m)	~f(m)	LZ~	Reel type	weight (kg)	nv(U)	n(U)	Z(N)	Order No.
•	7	1,0	0,5	2,0	VLF155-1-908-4-26	3,1	2	13	40	902 010
•	10	1,0	0,5	2,0	VLF180-1-931-4-26	10,5	3	18	60	902 020
	14	0,5	0,3	2,2	VLF220-2-951-4-26	19,5	2	18	200	902 101
	25	1,5	1,0	1,9	VLF300-2-972H4-26	52,0	17	25	165	902 293
	33	1,5	1,2	1,4	VLF420-2-983-4-36	56,0	3	24	240	901 595
	37	2,0	1,4	1,0	VLF530-2-985-4-36	110,0	5	22	265	901 592

Trommelflex Pur - HF 5 x 2,5 mm², Ø 13 mm, 0,23 kg/m

	l(m)	h(m)	~f(m)	LZ~	Reel type	weight (kg)	nv(U)	n(U)	Z(N)	Order No.
•	7	1,0	0,5	1,9	VLF155-1-908-5-26	3,1	2	13	40	902 016
•	10	1,0	0,6	3,0	VLF180-1-931-5-26	10,8	3	18	120	902 040
•	14	0,5	0,6	2,2	VLF220-2-951H5-26	19,5	4	18	100	902 132
	22	1,0	0,7	1,7	VLF300-2-952-5-26	31,0	2	22	210	902 321
	25	1,5	1,1	1,9	VLF300-2-972H5-26	52,0	17	25	165	902 325
	30	1,5	1,1	1,4	VLF420-2-983-5-36	56,0	5	22	240	902 442
	37	2,0	1,5	1,1	VLF530-2-985-5-36	110,0	5	22	267	901 593

Trommelflex Pur - HF 7 x 2,5 mm², Ø 14,7 mm, 0,315 kg/m

	l(m)	h(m)	~f(m)	LZ~	Reel type	weight (kg)	nv(U)	n(U)	Z(N)	Order No.
•	10	1,0	0,7	3,0	VLF180-1-931-7-26	11,0	3	18	60	902 043
	14	1,0	0,4	2,5	VLF220-2-951-7-26	20,0	2	18	200	902 162
	22	1,5	0,9	1,9	VLF300-2-952-7-26	31,0	2	22	210	902 351
•	26	2,0	1,6	2,2	VLF300-2-972H7-26	52,0	17	25	165	902 295
	31	2,0	1,6	1,6	VLF420-2-983-7-36	57,0	4	23	240	902 483
	34	2,0	1,7	1,1	VLF530-2-985-7-36	110,0	7	20	267	901 594

• The spring reelers are pre-assembled and available in two weeks ex works.

Trommelflex Pur - HF 12 x 2,5 mm², Ø 20,5 mm, 0,485 kg/m

	l(m)	h(m)	~f(m)	LZ~	Reel type	weight (kg)	nv(U)	n(U)	Z(N)	Order No.
•	10	1,5	1,0	2,0	VLF220-1-951-12-26	19,5	4	15	100	902 183
•	20	1,5	1,1	2,4	VLF300-2-952-12-26	30,0	6	18	210	902 371
	25	2,0	1,6	1,7	VLF300-2-972-12-36	58,0	10	17	240	902 375
	35	2,0	1,5	1,5	VLF530-2-986-12-36	132,0	2	20	490	903 799

Trommelflex Pur - HF 4 x 4 mm², Ø 13,4 mm, 0,28 kg/m

	l(m)	h(m)	~f(m)	LZ~	Reel type	weight (kg)	nv(U)	n(U)	Z(N)	Order No.
	7	1,0	0,5	2,0	VLF155-1-908-4-40	3,1	2	13	40	901 573
•	10	2,0	0,5	2,0	VLF180-1-931-4-40	8,5	4	17	60	901 102
	17	1,5	1,0	2,7	VLF220-2-951H4-40	20,0	14	21	100	902 114
	22	1,5	1,0	1,8	VLF300-2-952-4-40	31,0	2	22	200	902 301
	29	1,5	1,7	1,4	VLF420-2-983-4-42	57,0	7	20	240	902 412
	33	1,5	1,6	1,0	VLF530-2-986-4-42	90,0	2	20	245	903 806

Trommelflex Pur - HF 4 x 6 mm², Ø 14,9 mm, 0,372 kg/m

	l(m)	h(m)	~f(m)	LZ~	Reel type	weight (kg)	nv(U)	n(U)	Z(N)	Order No.
•	10	1,5	0,5	2,0	VLF220-1-951-4-60	19,0	3	16	100	902 120
	19	1,5	1,0	1,8	VLF300-1-972-4-60	28,0	2	19	165	901 401
	25	1,5	1,2	1,3	VLF420-2-983-4-60	57,0	8	18	240	902 424
	30	1,5	1,6	1,0	VLF530-2-985-4-60	110,0	9	18	267	901 581

Trommelflex Pur - HF 4 x 10 mm², Ø 18,8 mm, 0,61 kg/m

	l(m)	h(m)	~f(m)	LZ~	Reel type	weight (kg)	nv(U)	n(U)	Z(N)	Order No.
•	10	1,5	0,9	2,0	VLF220-1-951-4-60	19,0	3	15	100	902 120
	20	1,5	1,0	2,2	VLF300-2-972-4-60	28,0	2	19	330	902 313
•	23	1,5	1,7	1,6	VLF420-2-953-4-60	55,0	10	17	260	902 421
	30	1,5	1,4	1,3	VLF530-2-986-4-60	131,0	4	18	490	903 782

Trommelflex Pur - HF 4 x 16 mm², Ø 22,1 mm, 0,924 kg/m

	l(m)	h(m)	~f(m)	LZ~	Reel type	weight (kg)	nv(U)	n(U)	Z(N)	Order No.
•	12	1,5	1,0	2,0	VLF300-2-952-4-125	32,0	13	12	200	901 122
•	16	1,5	1,0	2,0	VLF300-2-972-4-125	36,0	4	16	330	901 267
	20	1,5	1,0	1,1	VLF530-2-986-4-150	131,0	10	12	490	903 785

Trommelflex Pur - HF 4 x 25 mm², Ø 25,5 mm 1,222 kg/m

	l(m)	h(m)	~f(m)	LZ~	Reel type	weight (kg)	nv(U)	n(U)	Z(N)	Order No.
•	10	1,5	0,8	2,0	VLF420-2-983-4-150	62,0	19	8	240	902 430
	18	1,5	1,0	1,1	VLF530-2-986-4-150	132,0	19	10	490	903 785

• The spring reelers are pre-assembled and available in two weeks ex works.

Reel selection table

for the application sample 8, random wrap, horizontal/vertical cable payout or steeply sloping

Trommelflex Pur - HF 4 x 1,5 mm², Ø 11,2 mm, 0,155 kg/m

	l(m)	LZ~	Reel type	weight (kg)	nv(U)	n(U)	Z(N)	Order No.
•	7	2,0	VLF155-1-908-4-26	3,1	2	13	40	902 010
	9	2,0	VLF155-2-908H4-26	3,7	4	16	40	902 012
•	12	2,0	VLF180-1-931-4-26	9,0	2	19	60	902 020
•	18	2,0	VLF180-2-931H4-26	11,0	4	30	60	902 022
•	26	4,0	VLF220-2-951H4-26	19,0	6	31	100	902 102
•	35	4,0	VLF300-2-952H4-26	28,0	4	36	100	902 291
	50	2,0	VLF301-3-972H4-26	58,0	9	51	165	901 587
	64	1,0	VLF530-2-986H4-36	115,0	4	38	250	901 566

Trommelflex Pur - HF 5 x 1,5 mm², Ø 11,8 mm, 0,178 kg/m

	l(m)	LZ~	Reel type	weight (kg)	nv(U)	n(U)	Z(N)	Order No.
•	7	3,0	VLF155-1-908-5-26	3,1	2	13	40	902 016
	8	3,0	VLF155-2-908H5-26	3,7	6	16	40	902 015
•	12	2,0	VLF180-1-931-5-26	9,5	3	18	60	902 040
•	18	3,0	VLF180-2-931H5-26	11,3	4	30	60	902 042
•	25	4,0	VLF220-2-951H5-26	19,0	4	33	100	902 132
•	31	3,0	VLF300-2-952H5-26	28,0	4	33	100	902 322
	33	2,0	VLF300-2-972H5-26	32,0	6	34	165	902 325
	50	3,0	VLF301-3-972H5-26	38,0	9	51	165	901 525
	64	2,0	VLF530-2-986H5-36	115,0	6	38	260	903 818

Trommelflex Pur - HF 7 x 1,5 mm², Ø 13,5 mm, 0,218 kg/m

	l(m)	LZ~	Reel type	weight (kg)	nv(U)	n(U)	Z(N)	Order No.
•	7	2,0	VLF155-1-908-7-26	3,1	2	13	40	902 008
•	10	2,0	VLF180-1-931-7-26	10,0	3	15	60	902 043
•	12	2,0	VLF220-1-951-7-26	18,0	3	16	100	902 160
•	20	4,0	VLF220-2-951H7-26	20,0	4	25	100	902 116
•	24	5,0	VLF221-2-951H7-26	22,8	4	33	100	902 282
•	34	3,0	VLF300-2-972H7-26	34,0	4	34	165	902 295
	41	3,0	VLF301-3-972H7-26	40,0	9	51	165	901 556
	49	3,0	VLF420-2-984H7-36	59,0	4	36	240	902 486
	63	2,0	VLF530-2-986H7-36	115,0	4	38	260	903 796

• The spring reelers are pre-assembled and available in two weeks ex works.

Trommelflex Pur - HF 12 x 1,5 mm², Ø 17,0 mm, 0,363 kg/m

	l(m)	LZ~	Reel type	weight (kg)	nv(U)	n(U)	Z(N)	Order No.
•	7	2,0	VLF180-1-931-12-26	10,0	10	12	60	902 058
•	12	3,0	VLF220-1-951-12-26	19,0	2	17	100	902 183
•	15	3,0	VLF220-2-951H12-26	22,5	14	22	100	901 364
•	22	3,0	VLF300-2-952-12-26	30,0	3	22	100	902 371
	26	3,0	VLF300-2-972H12-26	36,0	6	26	165	901 588
	32	2,0	VLF420-2-983-12-36	58,0	3	24	240	902 503
	40	3,0	VLF420-2-953-12-36	60,0	3	29	260	902 501
	50	1,8	VLKG530-5-925-12-36	128,0	4	29	400	901 557

Trommelflex Pur - HF 18 x 1,5 mm², Ø 18,1 mm, 0,459 kg/m

	l(m)	LZ~	Reel type	weight (kg)	nv(U)	n(U)	Z(N)	Order No.
•	7	2,0	VLF220-1-951-18-26	20,5	7	10	100	902 115
•	12	2,7	VLF221-2-951H18-26	25,0	18	17	200	902 281
•	23	3,0	VLF300-2-952-18-26	31,0	3	22	200	902 377
	28	2,0	VLF420-2-983-18-36	58,0	3	24	240	902 510
	31	3,0	VLF420-2-953-18-36	61,0	3	29	255	901 151
	34	2,0	VLF530-2-985-18-36	126,0	3	23	280	903 801
	48	2,0	VLKG530-5-925-18-36	150,0	6	27	500	901 558

Trommelflex Pur - HF 24 x 1,5 mm², Ø 20,9 mm, 0,590 kg/m

	l(m)	LZ~	Reel type	weight (kg)	nv(U)	n(U)	Z(N)	Order No.
•	9	2,0	VLF300-1-952-24-36	28,0	8	10	100	902 378
•	19	3,0	VLF300-2-952-24-36	31,0	7	18	200	902 380
•	22	2,0	VLF420-2-953-24-36	61,0	12	19	260	902 520
	25	2,0	VLF420-2-984-24-36	67,0	3	18	465	901 409
	32	2,0	VLF530-2-986-24-36	118,0	3	19	490	903 803
	36	1,7	VLKG530-4-925-24-36	128,0	5	20	480	901 559
	45	2,1	VLKG530-6-925-24-36	155,0	8	25	600	901 560

- The spring reelers are pre-assembled and available in two weeks ex works.

Reel selection table

for the application sample 8, random wrap, horizontal/vertical cable payout or steeply sloping

Trommelflex Pur - HF 30 x 1,5 mm², Ø 24,0 mm, 0,720 kg/m

	l(m)	LZ~	Reel type	weight (kg)	nv(U)	n(U)	Z(N)	Order No.
•	8	2,0	VLF300-1-952-30-36	28,0	10	10	100	902 390
•	16	2,0	VLF300-2-952-30-36	31,0	12	13	210	900 316
	18	3,0	VLF300-2-972-30-36	33,0	3	17	330	901 561
•	20	2,0	VLF420-2-953-30-36	65,0	9	16	260	901 437
	22	2,0	VLF420-2-984-30-36	66,0	3	17	470	901 453
	25	3,0	VLF421-2-984-30-36	69,0	3	18	470	901 562
	32	1,5	VLF530-2-986-30-36	118,0	3	19	500	903 805
	30	1,8	VLK530-4-925-30-36	128,0	10	17	480	901 563
	38	1,9	VLKG530-6-925-30-36	155,0	6	21	600	901 564

Trommelflex Pur - HF 4 x 2,5 mm², Ø 12,3 mm, 0,208 kg/m

	l(m)	LZ~	Reel type	weight (kg)	nv(U)	n(U)	Z(N)	Order No.
•	7	2,0	VLF155-1-908-4-26	3,1	2	13	40	902 010
•	10	2,0	VLF180-1-931-4-26	10,5	3	18	60	902 020
•	16	2,0	VLF180-2-931H4-26	11,0	10	28	60	902 022
•	26	4,0	VLF220-2-951H4-26	19,5	6	32	100	902 102
•	27	4,0	VLF300-2-952H4-26	25,0	9	28	100	902 291
	34	4,0	VLF300-2-972H4-26	52,0	6	28	165	902 293
	45	3,0	VLF301-3-972H4-26	55,0	9	51	165	901 587
	48	2,0	VLF420-2-984H4-36	56,0	6	36	235	901 393
	64	2,0	VLF530-2-986H4-36	114,0	6	38	250	901 566

Trommelflex Pur - HF 5 x 2,5 mm², Ø 13,0 mm, 0,230 kg/m

	l(m)	LZ~	Reel type	weight (kg)	nv(U)	n(U)	Z(N)	Order No.
•	7	2,0	VLF155-1-908-5-26	3,1	2	13	40	902 016
•	11	2,0	VLF180-1-931-5-26	10,0	3	18	60	902 040
•	14	2,0	VLF180-2-931H5-26	11,0	13	25	60	902 042
•	23	3,0	VLF220-2-951H5-26	19,5	6	32	100	902 132
	34	3,0	VLF300-2-972H5-26	52,0	6	34	165	902 325
	39	3,0	VLF301-3-972H5-26	58,0	9	51	165	901 525
	49	3,0	VLF420-2-984H5-36	61,0	6	36	240	900 825
	61	2,0	VLF530-2-986H5-36	112,0	6	38	250	903 818

• The spring reelers are pre-assembled and available in two weeks ex works.

Trommelflex Pur - HF 7 x 2,5 mm², Ø 14,7 mm, 0,315 kg/m

	l(m)	LZ~	Reel type	weight (kg)	nv(U)	n(U)	Z(N)	Order No.
	5	2,0	VLF155-1-908-7-26	4,0	4	10	40	902008
•	10	2,0	VLF180-1-931-7-26	10,0	4	17	60	902 043
•	12	3,0	VLF220-1-951-7-26	18,0	3	16	100	902 160
•	17	3,0	VLF220-2-951H7-26	19,0	10	25	100	902 116
•	18	4,0	VLF221-2-951H7-26	20,0	10	25	100	902 282
•	30	3,0	VLF300-2-972H7-26	34,0	8	30	240	902 295
	39	2,0	VLF420-2-953-7-36	59,0	3	29	260	901 567
	43	2,0	VLF420-2-984H7-36	62,0	6	36	240	902 486
	47	2,0	VLF530-2-986H7-36	115,0	6	38	250	903 796
	50	1,3	VLKG530-5-925-7-36	130,5	4	29	400	901 568

Trommelflex Pur - HF 12 x 2,5 mm², Ø 20,5 mm, 0,485 kg/m

	l(m)	LZ~	Reel type	weight (kg)	nv(U)	n(U)	Z(N)	Order No.
•	10	3,0	VLF220-1-951-12-26	19,5	4	15	100	902 183
•	12	3,0	VLF221-2-951H12-26	23,5	15	17	100	902 283
•	23	3,0	VLF300-2-952-12-26	30,0	3	22	210	902 371
	28	2,0	VLF420-2-983-12-36	58,0	7	20	240	902 503
	30	3,0	VLF420-2-953-12-36	69,0	10	22	260	902 501
	33	2,0	VLF530-2-985-12-36	110,0	7	19	280	903 810
	40	1,8	VLK530-4-925-12-36	128,0	4	23	480	901 569
	50	2,1	VLKG530-6-925-12-36	145,0	5	28	600	901 570

Trommelflex Pur - HF 18 x 2,5 mm², Ø 20,6 mm, 0,679 kg/m

	l(m)	LZ~	Reel type	weight (kg)	nv(U)	n(U)	Z(N)	Order No.
•	8	2,0	VLF220-1-951-18-26	20,5	7	10	100	902 115
	16	3,0	VLF300-2-952-18-36	32,0	10	15	200	903 836
	17	3,0	VLF300-2-972-18-36	34,0	3	17	330	901 129
•	20	2,0	VLF420-2-983-18-36	60,0	13	14	240	902 510
	21	2,0	VLF420-2-953-18-36	62,0	14	16	260	901 151
	24	2,0	VLF420-2-984-18-36	63,0	3	18	470	902 522
	32	2,0	VLF530-2-986-18-36	110,0	3	19	500	903 802
	35	1,5	VLKG530-5-925-18-36	143,0	7	20	600	901 558
	43	1,9	VLKG530-6-925-18-36	145,0	3	24	725	901 571

• The spring reelers are pre-assembled and available in two weeks ex works.

Reel selection table

for the application sample 8, random wrap, horizontal/vertical cable payout or steeply sloping

Trommelflex Pur - HF 24 x 2,5 mm², Ø 23,6 mm, 0,860 kg/m

	l(m)	LZ~	Reel type	weight (kg)	nv(U)	n(U)	Z(N)	Order No.
•	11	2,0	VLF300-1-972-24-36	35,0	5	10	165	902 438
•	22	3,0	VLF300-2-972-24-36	38,0	2	18	330	902 294
	25	3,0	VLF421-2-984-24-36	64,0	3	18	470	901 572
	33	2,0	VLF530-2-986-24-36	110,0	3	19	490	903 803
	28	1,6	VLKG530-5-925-24-36	143,0	11	16	600	901 538
	38	2,0	VLKG530-6-925-24-36	145,0	6	21	725	901 560

Trommelflex Pur - HF 30 x 2,5 mm², Ø 28,2 mm, 1,080 kg/m

	l(m)	LZ~	Reel type	weight (kg)	nv(U)	n(U)	Z(N)	Order No.
•	7	1,0	VLF420-1-983-30-36	57,0	19	6	120	902 525
•	14	2,0	VLF420-2-983-30-36	60,0	17	10	240	901 115
	15	2,0	VLF420-2-953-30-36	62,0	20	11	260	901 437
	20	2,0	VLF420-2-984-30-36	65,0	7	14	470	901 453
	26	3,0	VLF421-2-984-30-36	67,0	3	18	470	901 562
	30	2,0	VLF530-2-986-30-36	110,0	5	17	500	903 805
	32	2,0	VLKG530-6-925-30-36	145,0	9	18	725	901 564

Trommelflex Pur - HF 4 x 4 mm², Ø 13,6 mm, 0,281 kg/m

	l(m)	LZ~	Reel type	weight (kg)	nv(U)	n(U)	Z(N)	Order No.
	5	2,0	VLF155-1-908-4-40	3,5	3	11	40	901 573
•	10	3,0	VLF180-1-931-4-40	10,5	4	17	60	901 102
•	12	3,0	VLF220-1-951-4-40	18,0	3	16	100	902 110
	17	2,0	VLF220-2-951H4-40	20,0	12	22	100	902 114
•	20	3,0	VLF221-2-951H4-40	21,0	10	26	100	902 214
•	22	1,9	VLF300-2-952H4-40	31,0	2	23	100	902 302
•	34	3,0	VLF300-2-972H4-40	37,0	6	34	180	901 315
	39	2,0	VLF420-2-953-4-42	60,0	3	29	260	901 574
	48	3,0	VLF420-2-984H4-42	64,0	6	36	470	901 575
	52	2,0	VLF530-2-986H4-42	104,0	6	38	250	901 576

- The spring reelers are pre-assembled and available in two weeks ex works.

Trommelflex Pur - HF 5 x 4 mm², Ø 14,5 mm, 0,318 kg/m

	l(m)	LZ~	Reel type	weight (kg)	nv(U)	n(U)	Z(N)	Order No.
	5	2,0	VLF155-1-908-5-40	4,0	3	11	40	902 019
	8	2,0	VLF180-1-931-5-40	11,0	7	14	60	901 287
	12	3,0	VLF220-1-951-5-40	18,0	3	16	100	902 140
	17	3,0	VLF220-2-951H5-40	20,0	12	22	100	902 143
	21	2,0	VLF300-2-952-5-40	28,0	3	22	200	902 330
	29	3,0	VLF300-2-972H5-40	31,0	8	29	165	901 363
	32	2,0	VLF420-2-983-5-42	58,0	3	24	240	902 452
	39	2,0	VLF420-2-953-5-42	60,0	3	29	260	901 577
	42	3,0	VLF420-2-984H5-42	63,0	6	36	240	901 578
	45	2,0	VLF530-2-986H5-42	110,0	6	38	250	901 579

Trommelflex Pur - HF 4 x 6 mm², Ø 14,9 mm, 0,372 kg/m

	l(m)	LZ~	Reel type	weight (kg)	nv(U)	n(U)	Z(N)	Order No.
•	12	3,0	VLF220-1-951-4-60	19,0	3	16	100	902 120
	15	3,0	VLF220-2-951H4-60	20,0	14	18	100	902 107
•	25	3,0	VLF300-2-972H4-60	59,0	13	25	165	901 309
	32	2,0	VLF420-2-983-4-60	56,0	3	24	240	902 424
	39	2,0	VLF420-2-953-4-60	59,0	3	29	260	902 421
	42	1,6	VLK530-4-925-4-60	130,5	3	24	400	901 565

Trommelflex Pur - HF 5 x 6 mm², Ø 16,1 mm, 0,435 kg/m

	l(m)	LZ~	Reel type	weight (kg)	nv(U)	n(U)	Z(N)	Order No.
	9	2,0	VLF220-1-951-5-60	18,0	7	12	100	902 150
	12	3,0	VLF220-2-951-5-60	20,0	3	16	200	902 142
	13	3,0	VLF220-2-951H5-60	22,0	16	18	100	901 499
	22	3,0	VLF300-2-952-5-60	31,0	3	22	200	902 341
	31	2,0	VLF420-2-983-5-60	57,0	3	24	240	902 464
	34	2,0	VLF420-2-953-5-60	59,0	6	26	260	902 461
	37	2,0	VLF530-2-985-5-60	112,0	3	23	280	903 808
	42	1,4	VLK530-4-925-5-60	130,5	3	24	480	901 580

• The spring reelers are pre-assembled and available in two weeks ex works.

Reel selection table

for the application sample 8, random wrap, horizontal/vertical cable payout or steeply sloping

Trommelflex Pur - HF 4 x 10 mm², Ø 18,9 mm, 0,615 kg/m

	l(m)	LZ~	Reel type	weight (kg)	nv(U)	n(U)	Z(N)	Order No.
•	7	2,0	VLF220-1-951-4-60	19,0	9	10	100	902 120
•	13	3,0	VLF220-2-951-4-60	21,0	2	16	200	902 123
•	15	2,0	VLF300-2-972H4-60	30,0	18	17	165	901 309
	18	2,0	VLF300-2-952-4-60	31,0	5	20	200	902 311
	22	2,0	VLF420-2-983-4-60	56,0	11	16	240	902 424
•	24	2,0	VLF420-2-953-4-60	59,0	16	16	260	902 421
	26	2,0	VLF530-2-985-4-60	108,0	11	15	280	901 581
	32	2,0	VLF530-2-986-4-60	110,0	3	19	500	903 782
	42	1,7	VLKG530-5-925-4-60	135,0	3	24	600	901 582
	44	2,1	VLKG530-6-925-4-60	148,0	8	25	600	901 583

Trommelflex Pur - HF 4 x 16 mm², Ø 22,1 mm, 0,924 kg/m

	l(m)	LZ~	Reel type	weight (kg)	nv(U)	n(U)	Z(N)	Order No.
•	6	1,0	VLF300-1-952-4-125	29,0	17	7	100	901 443
•	12	2,0	VLF300-2-952-4-125	32,0	13	12	200	901 122
•	18	2,0	VLF300-2-972-4-125	36,0	3	17	330	901 267
	25	2,0	VLF420-2-984-4-150	64,0	3	18	470	901 317
	31	2,0	VLF530-2-986-4-150	115,0	4	18	500	903 785
	35	2,1	VLKG530-6-925-4-150	150,0	3	24	720	901 586

Trommelflex Pur - HF 4 x 25 mm², Ø 25,5 mm, 1,222 kg/m

	l(m)	LZ~	Reel type	weight (kg)	nv(U)	n(U)	Z(N)	Order No.
•	10	2,0	VLF420-2-983-4-150	62,0	19	8	240	902 430
	20	2,0	VLF420-2-984-4-150	64,0	6	15	470	901 317
	21	2,0	VLF421-2-984-4-150	67,0	4	17	470	901 585
	23	2,0	VLF530-2-986-4-150	115,0	10	12	500	903 785
	25	1,5	VLKG530-6-925-4-150	150,0	13	14	720	901 586

Trommelflex Pur - HF 4 x 35 mm², Ø 30,0 mm, 1,780 kg/m

	l(m)	LZ~	Reel type	weight (kg)	nv(U)	n(U)	Z(N)	Order No.
	8	1,0	VLF420-2-953-4-150	66,0	24	7	260	902 427
	15	2,0	VLF420-2-984-4-150	68,0	10	11	470	901 317
	17	2,0	VLF530-2-986-4-150	115,0	12	10	500	903 785
	19	1,3	VLKG530-6-925-4-150	150,0	17	10	720	901 586

• The spring reelers are pre-assembled and available in two weeks ex works.

Cable reels (with fixing flange)

Random wrap - Dimensions

Attention!
Please consider enough space to put off the slipping cover.

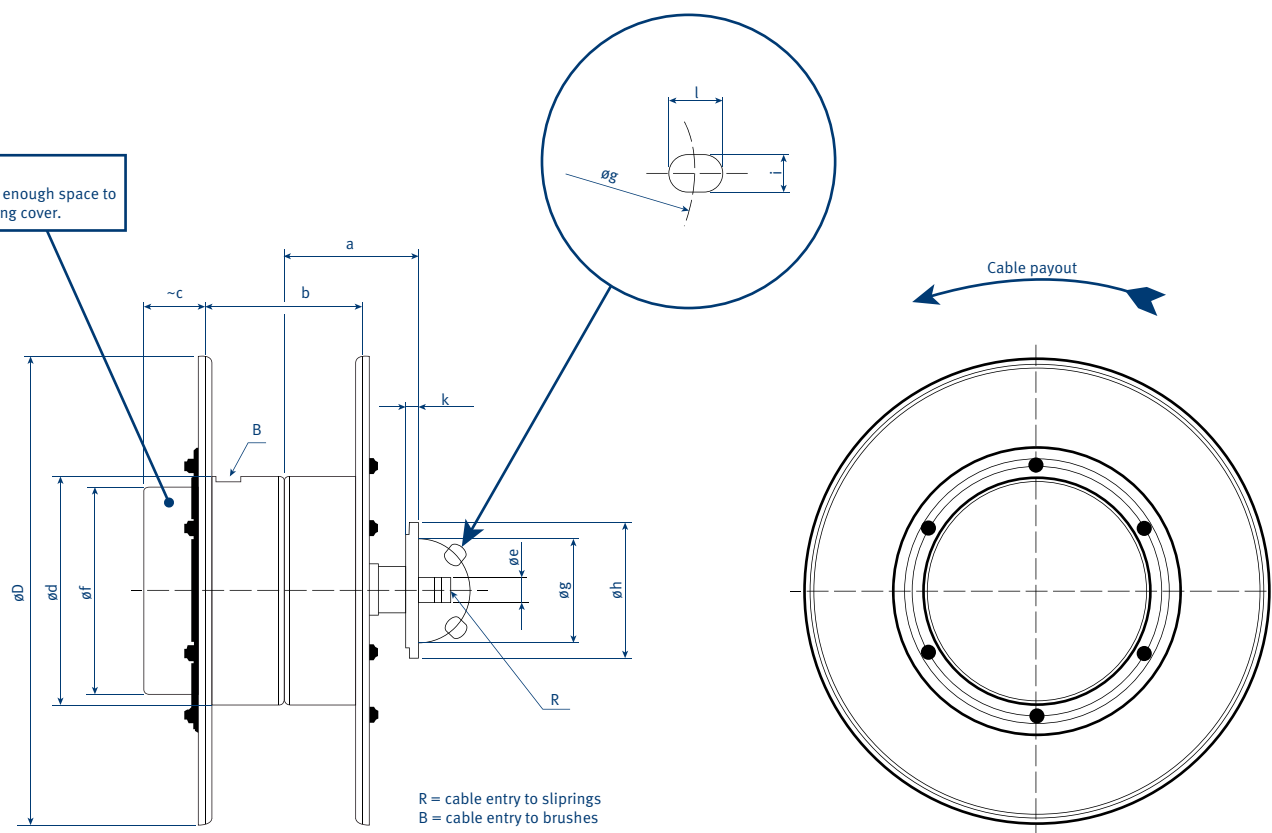

Table 6: Reel dimensions (mm)

Type ⁽¹⁾	$\varnothing d$	$\varnothing D$	b	a	$\sim c$	$\varnothing f$	e	$\varnothing g$	$\varnothing h$	i	l	k	weight ⁽²⁾ kg
VLF 155	155	260	110	101,5	80	155	25	65	85	4 x $\varnothing 9$	-	10	2,5
VLF 180	180	290	130	113	110	170	25	65	85	4 x $\varnothing 9$	-	10	6,5
VLF 220	220	400	120	114	80	220	25	100	130	4 x $\varnothing 13$	20	9	13,0
VLF 221	220	450	150	130	80	220	25	100	130	4 x $\varnothing 13$	20	9	14,0
VLF 222	220	450	170	139	50	220	25	100	130	4 x $\varnothing 13$	20	12	14,0
VLF 300	300	550	190	165	125	300	35	100	135	4 x $\varnothing 13$	20	20	16,0
VLF 301	300	550	285	213	80	300	35	100	135	4 x $\varnothing 13$	21	20	18,0
VLF 420	420	680	240	200	165	420	45	130	178	4 x $\varnothing 17$	23	20	35,0
VLF 421	420	770	240	200	165	420	45	130	215	4 x $\varnothing 17$	23	20	40,0
VLF 530	530	900	310	255	85	420	70	185	250	4 x $\varnothing 18$	32	23	80,0

Spring reference	908	931	951	952	953	972	983	984	985	986
weight approx. kg	0,868	2,286	2,994	5,288	10,610	5,891	8,532	10,846	15,120	21,510

1) Full type details in selection chart
2) Base weight w/o springs (3 poles + PE)
Total weight = Base weight + weight of springs

Cable reels (with fixing flange)

Random wrap - Dimensions

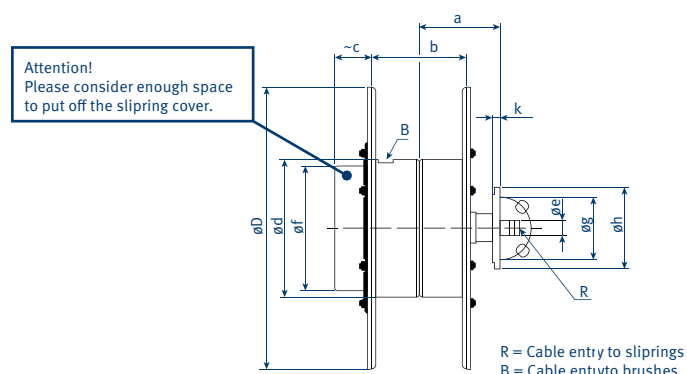

Table 7: Max. pole amounts - Cover dimensions (mm)

Type ⁽¹⁾	Amps ⁽²⁾	Dim. "c" of enclosures (mm) for Std. Assys incl. Ground (staggered)								Drilling drum shaft mm	Cable gland M	
		3	4	6	7	11	17	23	29		R	B
VLF 155	26	60	80	80	100					14	M20 x 1,5	M20 x 1,5
VLF 180	26	50	50	90						18	M20 x 1,5	M20 x 1,5
VLF 180	40	50	50	90	90					18	M20 x 1,5	M20 x 1,5
VLF 220	26	50	50	100	100	150				18	M20 x 1,5	M32 x 1,5
VLF 220	42	75	75	100	100	200				18	M20 x 1,5	M32 x 1,5
VLF 220	40	50	50	100	100	150				18	M20 x 1,5	M32 x 1,5
VLF 220	60	75	100							18	M20 x 1,5	M32 x 1,5
VLF 221	26	50	50	75	75	130				18	M20 x 1,5	M32 x 1,5
VLF 221	42	50	50	75	100	130				18	M20 x 1,5	M32 x 1,5
VLF 221	40	50	50	75						18	M20 x 1,5	M32 x 1,5
VLF 221	60	50	75	100						18	M20 x 1,5	M32 x 1,5
VLF 222	26	50	50	100	100	150				18	M20 x 1,5	M32 x 1,5
VLF 222	42	75	75	100	100	200				18	M20 x 1,5	M32 x 1,5
VLF 222	40	50	50	100	100	150				18	M20 x 1,5	M32 x 1,5
VLF 222	60	75	100							18	M20 x 1,5	M32 x 1,5
VLF 300	26	80	80	80	120	150				24	M32 x 1,5 ⁽³⁾	M40 x 1,5
VLF 300	42	80	80	120	120	200		320		24	M32 x 1,5 ⁽³⁾	M40 x 1,5
VLF 300	40	80	80	80	120					24	M32 x 1,5 ⁽³⁾	M40 x 1,5
VLF 300	60	80	80							24	M32 x 1,5 ⁽³⁾	M40 x 1,5
VLF 301	26	20	20	90	90	130				16	M20 x 1,5	M40 x 1,5
VLF 301	42	20	90	90	90	90		180		16	M20 x 1,5	M40 x 1,5
VLF 301	40	20	20	90	90	130				16	M20 x 1,5	M40 x 1,5
VLF 301	60	20	90	90	90					16	M20 x 1,5	M40 x 1,5
VLF 420/421	42	85	85	135	135	165	265	335		32	M32 x 1,5 ⁽³⁾	M50 x 1,5
VLF 420/421	60	85	85							32	M32 x 1,5 ⁽³⁾	M50 x 1,5
VLF 420/421	150	85	85							32	M32 x 1,5 ⁽³⁾	M50 x 1,5
VLF 530	42	85	85	85	85	85	155	270	400	40	M50 x 1,5	M63 x 1,5
VLF 530	60	85								40	M50 x 1,5	M63 x 1,5
VLF 530	150	85								40	M50 x 1,5	M63 x 1,5

1) Full type details in selection chart
 2) Current rating with 100% duty cycle
 3) Springs with 3 drive spring -> R = M20 x 1,5

Cable reels (with console)

Random wrap - Dimensions

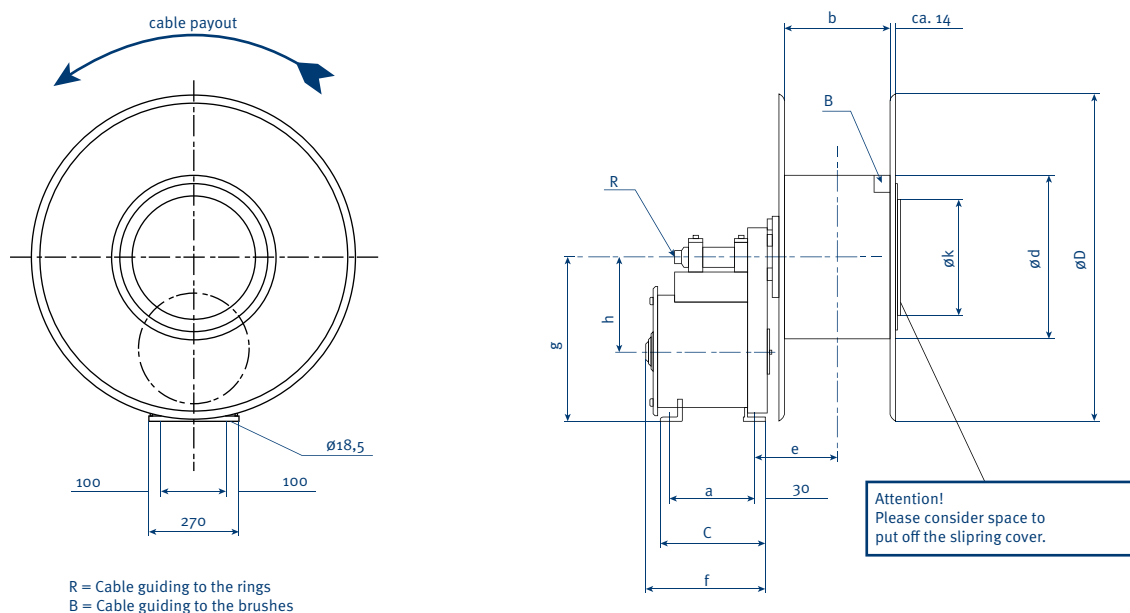

Table 8: Reel dimensions (mm)

Type ⁽¹⁾	Drum Dimensions			a	c	e	f	g	h	k	weight ⁽²⁾ kg
	ø d	ø D	ø b								
VLK 530	530	900	310	260	320	248	358	500	290	420	135
VLKG 530	530	1000	310	390	446	248	488	500	290	420	140
VLKG 700	700	1200	350	390	446	255	488	500	290	370	170
Spring reference	924					925					
weight approx. kg	11,900					14,000					

Table 9: Max. pole amounts - Cover dimensions (mm)

Type ⁽¹⁾	Amps ⁽³⁾	Dim. of enclosures (mm) for Std. Assys incl. Ground (staggered)					Cable gland M	
		7	11	17	23	29	R	B
VLK 530	42	27	27	50	105	200	M50 x 1,5	depending on reel body (measurement upon request)
VLKG 530	42	27	27	50	105	200	M50 x 1,5	
VLKG 700	42	27	27	50	105	200	M50 x 1,5	

1) Full type details in selection chart
 2) Base weight w/o springs (3 poles + PE)
 Total weight = Base weight + weight of springs
 3) Current rating with 100% duty cycle

Accessories

Ratchet device, rotating, wall mounting



Ratchet Device (one lock position per full reel turn)

Type	for reel	Order-No.
EKV 155	VLf 155	901 720
EKV 180	VLf 180	901 721
EKV 220	VLf 220/221/222	901 722
EKV 300	VLf 300/301	901 723
EKV 420	VLf 420/421	901 724
EKV 530	VLf 530	901 726



Swivel Base • Rotation 150° • Wall Mounting⁽¹⁾

Type	for reel	Order-No.
SWB 155	VLf 155	901 730
SWB 180	VLf 180	901 731
SWB 220	VLf 220/221	901 732
SWB 300	VLf 300	901 733
SWB 420	VLf 420/421	901 734
SWB 530	VLf 530	901 736

1) cable guide arm must be used

Accessories

Rotating ceiling mounting, rigid wall or floor mounting



Pivot Base - Rotation 300° - Ceiling Mounting⁽¹⁾

Type	for reel	Order-No.
SDB 155	VLf 155	901 740
SDB 180	VLf 180	901 741
SDB 220	VLf 220/221	901 742
SDB 300	VLf 300	901 743
SDB 420	VLf 420/421	901 744
SDB 530	VLf 530	901 746

1) cable guide arm must be used

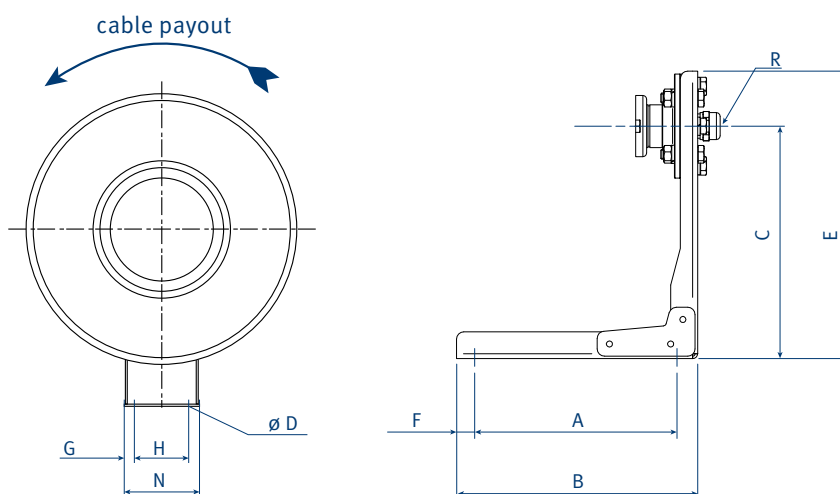

Rigid wall or floor mounting

Type	A	B	C	E	F	H	N	Ø D	Order-No.
STB 155	165	197	190	235	15	110	154	8,5	901 867
STB 180	165	197	190	235	15	110	154	8,5	900 694
STB 220	210	249	279	409	15	110	165	13	901 063
STB 221	210	249	279	409	15	110	165	13	901 868
STB 300	210	249	329	409	15	110	165	13	901 870
STB 301	210	249	329	409	15	110	165	13	901 871
STB 420	310	379	454	564	35	200	283	17	901 872
STB 421	310	379	454	564	35	200	283	17	901 869
STB 530	310	380	565	705	35	200	283	17	901 598

Accessories

Cable guide arm for free swinging roller type



Cable guide arm for free swinging roller type

Type	for reel	Order-No.
RFAS 155	VLF 155	902 062
RFAS 180	VLF 180	902 063
RFAS 220	VLF 220	902 064
RFAS 221	VLF 221	902 065
RFAS 300	VLF 300	902 066
RFAS 420	VLF 420	902 067
RFAS 421	VLF 421	902 068
RFAS 530	VLF 530	902 069

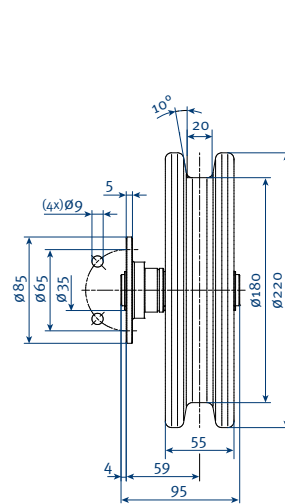

ULRB 180

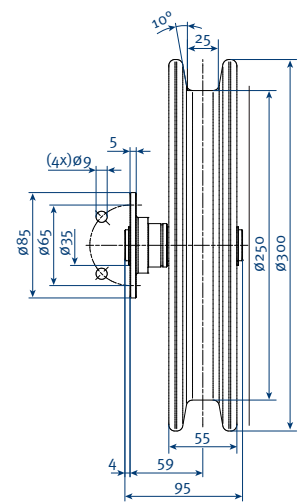

ULRB 250

Guide roller with mounting flange

Type	Description	Order-No.
ULRB 180	Roll diameter 180 mm	901 978
ULRB 250	Roll diameter 250 mm	901 979

Accessories

Sheave guide

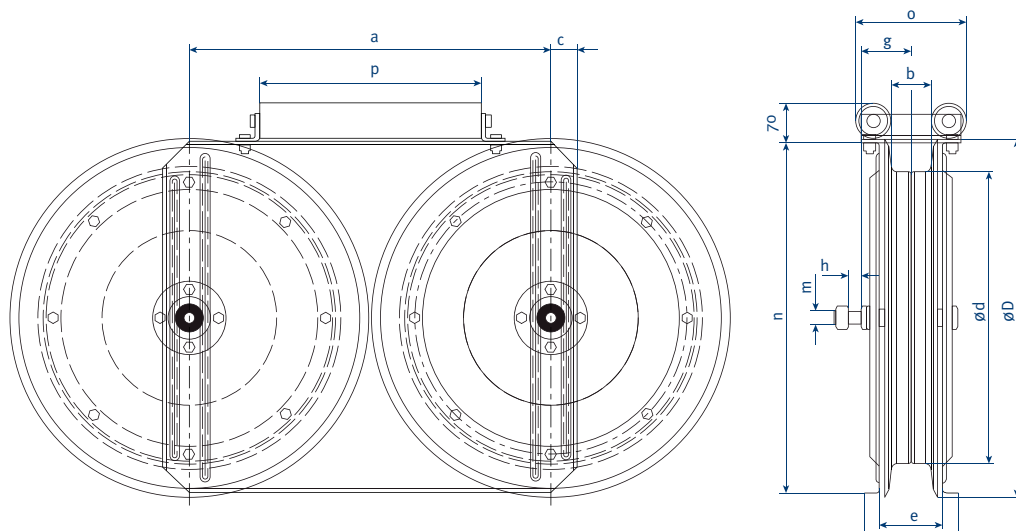

Sheave guide with additional top guide roller

Type	mm ²	a	b	c	ø d	ø D	e	f	g	h	m	n	o	p	Order-No.
SU-R 1	4 x 6	455	70	32,5	350	450	114	170	85	50	M 24	445	180	315	901 630
SU-R 2	4 x 16	655	70	47,5	503	650	114	170	85	50	M 24	640	180	400	901 631
SU-R 3	4 x 35	785	70	80	663	780	114	170	85	50	M 24	770	180	500	901 632
SU-R 4	4 x 70	905	75	80	783	900	114	170	85	50	M 24	890	180	600	901 633
SU-R 5	4 x 95	1105	80	73	900	1100	134	192	103	62	M 30	1090	210	800	901 634

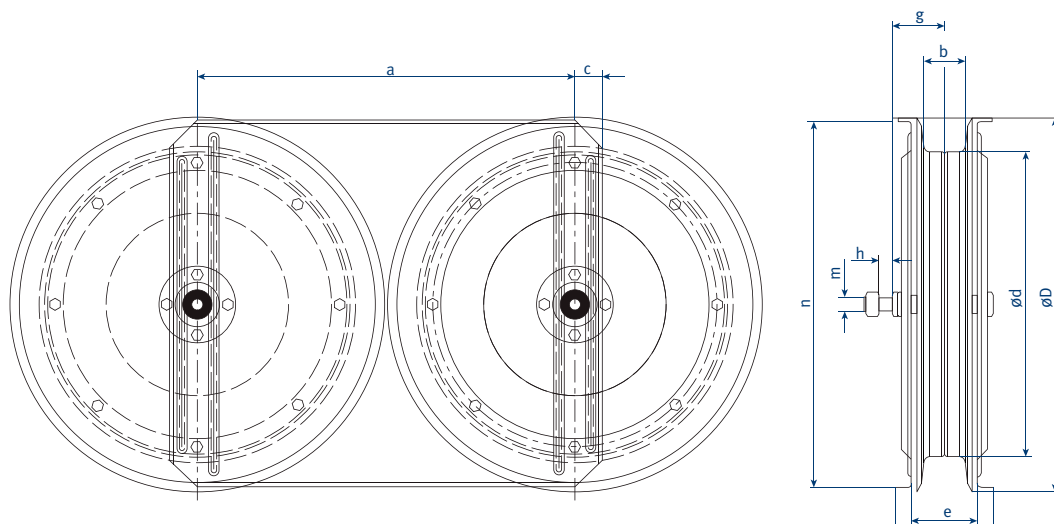

Sheave guide w/o top guide roller

Type ¹	mm ²	a	b	c	ø d	ø D	e	f	g	h	m	n	o	p	Order-No.
SU 1	4 x 6	455	70	32,5	350	450	114	170	85	50	M 24	445	180	315	901 635
SU 2	4 x 16	655	70	47,5	503	650	114	170	85	50	M 24	640	180	400	901 636
SU 3	4 x 35	785	70	80	663	780	114	170	85	50	M 24	770	180	500	901 637
SU 4	4 x 70	905	75	80	783	900	114	170	85	50	M 24	890	180	600	901 638
SU 5	4 x 95	1105	80	73	900	1100	134	192	103	62	M 30	1090	210	800	901 639

Accessories

Cable support roller, cable wire grip

The support rollers will be supplied with screws and spring washers

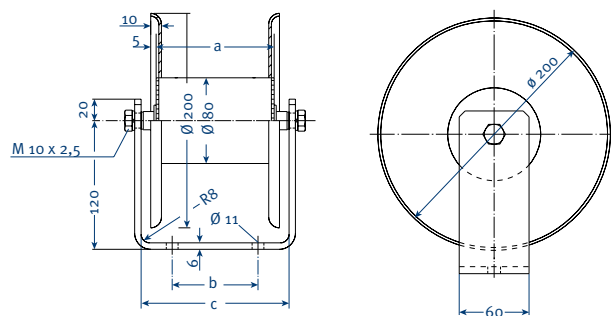

Cable support roller

Type		weight kg	a	b	c	Order-No.
TR 80/110 B 200	w/o bracket	2,25	110	–	130	924 450
TR 80/300 B 200		3,25	300	–	320	924 460
TR 80/500 B 200		4,50	500	–	520	924 470
TR 80/110 B 200 H	with bracket	3,50	110	80	130	924 480
TR 80/300 B 200 H		5,15	300	250	320	924 490
TR 80/500 B 200 H		6,90	500	400	520	924 500

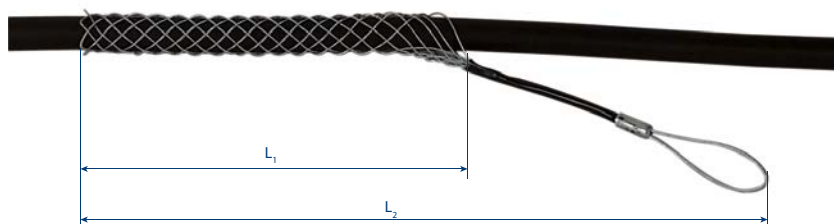

Cable wire grip

Typ	for cable diameter (mm)	max. allowed tension ⁽¹⁾ kg	meshwork length dimension L ₁	meshwork length dimension L ₂	Order-No.
VLZK 6	4 – 7	60	100	275	900 391
VLZK 9	7 – 9	110	120	290	900 392
VLZK 12	9 – 12	130	135	340	900 393
VLZK 15	12 – 15	210	180	390	900 394
VLZK 20	15 – 20	260	220	450	900 395
VLZK 25	20 – 25	260	275	510	900 396
VLZK 30	25 – 30	400	350	610	900 397
VLZK 40	30 – 40	580	370	660	900 398

1) calculated with three-fold safety

Accessories

Feed-in funnel, turnover anchor clamps

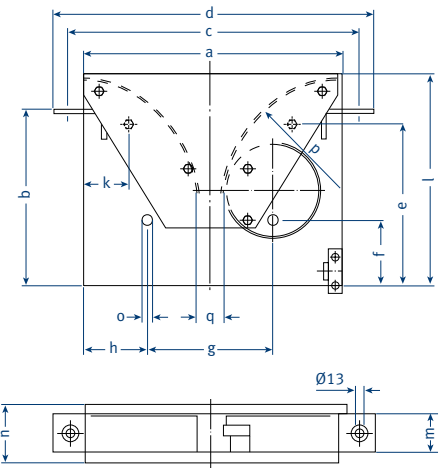

For all travel speeds and frequent passing over center point.

Feed-in funnel incl. tension relief reel (for voltages upto 1000V)

Type	cable dia. max Ø mm	a	b	c	d	e	f	g	h	i	k	l	m	n	o	p	q	weight kg	Order-No.
ETZV 1	19	350	240	390	430	220	90	170	85	220	60	290	50	80	13	150	40	4,93	928 248
ETZV 2	21	425	270	465	505	220	78	202	98	360	20	300	70	110	13	175	40	9,00	928 249
ETZV 3	29	540	495	670	720	405	310	300	360	400	70	530	100	140	13	270	55	16,00	928 250
ETZV 4	38	820	650	920	970	550	200	400	210	740	40	700	140	180	17	400	80	30,00	928 251

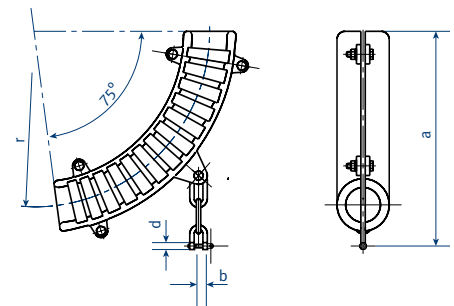

Turnover anchor clamps (for voltages upto 1000V)

Type	weight kg	Cable diameter (mm)	r	a	d	b	Order-No.
LS 1	1,6	21,5	100	205	10	14	921 420
LS 2	2,5	> 21,5 – 28	130	225	10	14	921 430
LS 3	3,5	> 28 – 36,5	170	265	12	17	921 440
LS 4	5,5	> 36,5 – 48	220	300	12	17	921 450

Spare parts

The following spare parts are available for all reelers listed in this catalogue.

For determination refer to related table, type label and type code.

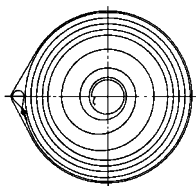

	Reel type
Reel Series	VLK 220 - 2 - 951H - 4 - 26
Drum diameter	VLK 530 - 2 - 985 - 4 - 150
No. of Springs	VLKG 700 - 6 - 915 - 4 - 220 - A
Spring Series	
No. of Poles incl. Ground	
Amps	
Suffix for opposite rotation	

Springs

Type ⁽¹⁾	weight	drill hole mm	outer diam. mm	width mm	Order-No.
908	0,600	35	126	18	901 640
910	0,500	25	114	18	901 641
931	2,300	35	160	25	901 642
951	2,950	35	190	30	901 643
952	5,500	45	280	45	901 645
972	6,000	45	280	45	901 646
903	6,200	50	315	60	901 648
953	13,200	60	400	60	901 684
983	10,350	60	400	60	901 685
924	11,900	50	315	60	901 687
925	15,000	50	315	60	901 689
965	10,800	65	315	60	901 704
975	18,000	65	315	60	901 705
984	12,000	85	380	60	900 618
985	17,000	85	450	60	901 706
986	25,500	85	450	60	901 707

Note! Never remove springs from protection bandage and handle replaced springs carefully.

1) The spring types 908 to 986 substitute former types 508 to 586.

Spare parts

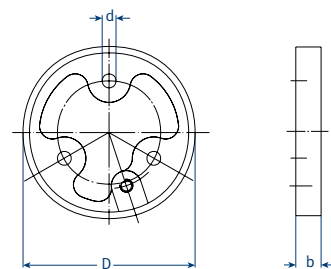

Sliprings

Amps A	Dimensions				Order-No.	
	D mm	d		b mm	Phase	Ground
		Phase	Ground			
26 ⁽¹⁾	50	8,5	5,5	10	901 670	901 671
36 ⁽²⁾	80	12,5	8,5	10	901 672	901 673
40	50	8,5	5,5	10	901 674	901 675
42	80	12,5	8,5	10	901 682	901 683
60	80	12,5	8,5	12	901 676	901 677
125	97	8,5	12,5	15	970 765	970 766
150	130	12,5	8,5	15	901 678	901 679
220	130	12,5	8,5	20	901 680	901 681

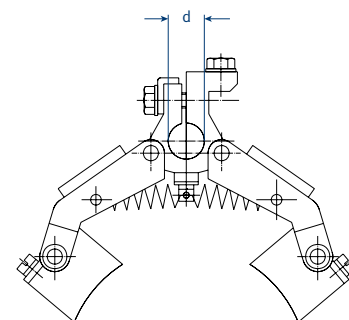

Brush Assemblies

Amps A	Dimensions d (mm)		Order-No.	
	Phase	Ground	Phase	Ground
26 ⁽¹⁾	10	8	901 690	901 691
36 ⁽²⁾	10	8	901 692	901 693
40	10	8	901 694	901 695
42	10	8	901 702	901 703
60	13	12	901 696	901 697
125	16	15	970 767	970 768
150	16	15	901 698	901 699
220	17	16	901 700	901 701

1 Corresponds to former type 25 A or 30 A

2 Corresponds to former type 30 A (max. cross section 2,5 mm²)
For larger cross sections use 42 A brush assembly.

Questionnaire

Co.: _____

Date: _____

Fon.: _____

Fax: _____

E-Mail: _____

Internet: _____

1. For what type of moving equipment is the reel? _____
A rough sketch based on the typical applications shown on page 5 of this catalog is extremely valuable.

2. Reel installation height h= _____ m

3. Travel distance of equipment _____ m

4. Cable payout from center from one end

5. What is the max. cable length on the reel? l= _____ m
Midway feed-point cuts the length of cable needed in half.

6. Type of Cable (number of conductors x wire size) _____ x _____ mm²

weight _____ kg/m

outside dia. _____ mm

7. Electrical load _____ kW

Voltage _____ V

Amps _____ A

8. Reduction factor due to cranes working simultaneously? _____ %

9. No. of Collector Rings required? _____ pc.
(our slipping assemblies always include one ground)

10. Type of application? (see page 7) No.

11. How many movements per hour? _____ times

12. Operating hours per day? _____ h

13. Maximum travel/lift speed? _____ m/min

14. Acceleration 0 to full in _____ sec

15. Acceleration rate _____ m/sec²

Motor data	Crane 1			Crane 2			Crane 3		
	Power kW/HP	Current Amps.	Duty factor %	Power kW/HP	Current Amps.	Duty factor %	Power kW/HP	Current Amps.	Duty factor %
Hoist motor									
Auxiliary hoist									
Travel motor - main-trolley									
Travel motor - aux.-trolley									
Main travel									
Slewing									
Luffing									

Mark with an "E" any motor that may be in simultaneous operation.

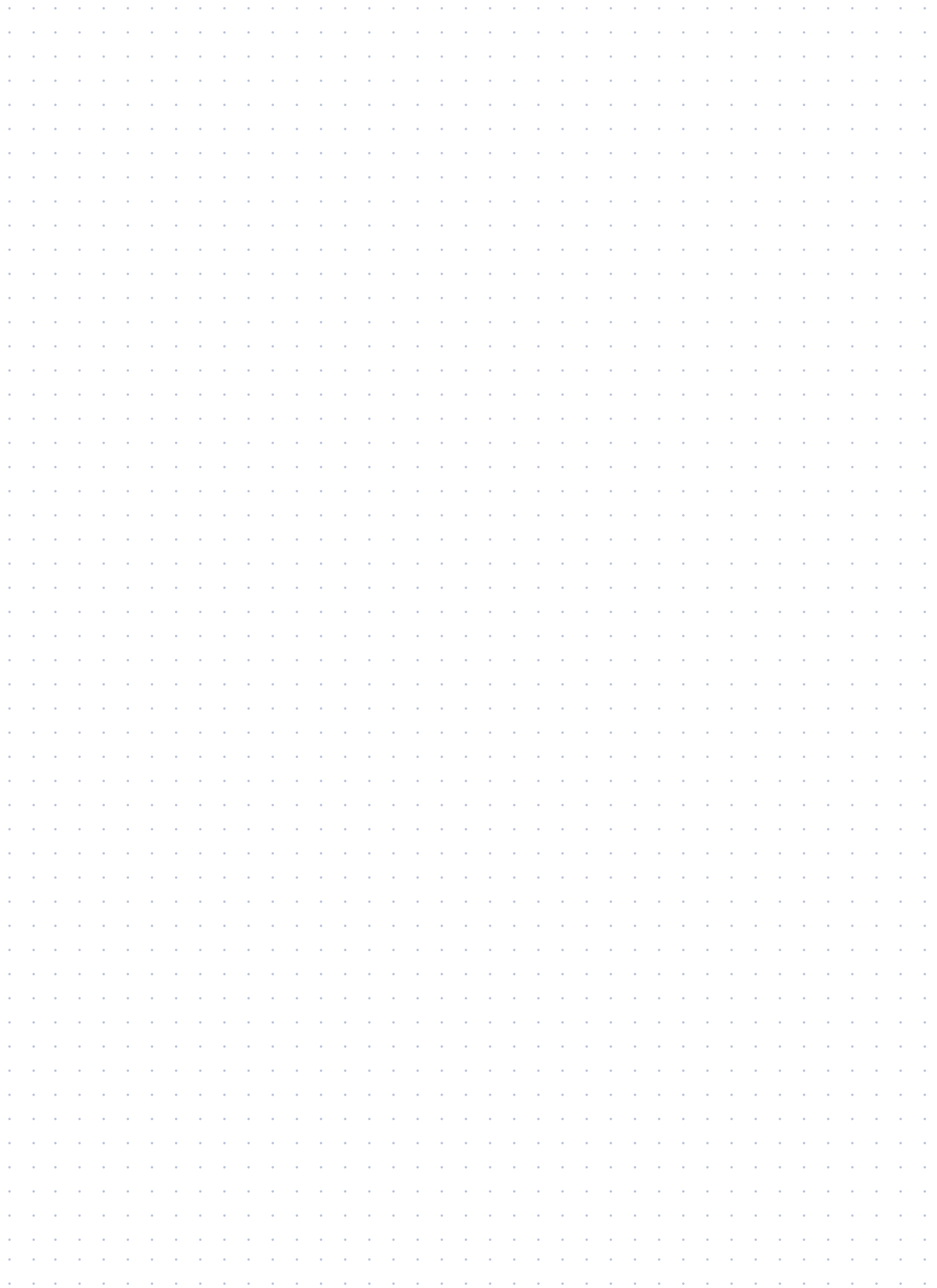

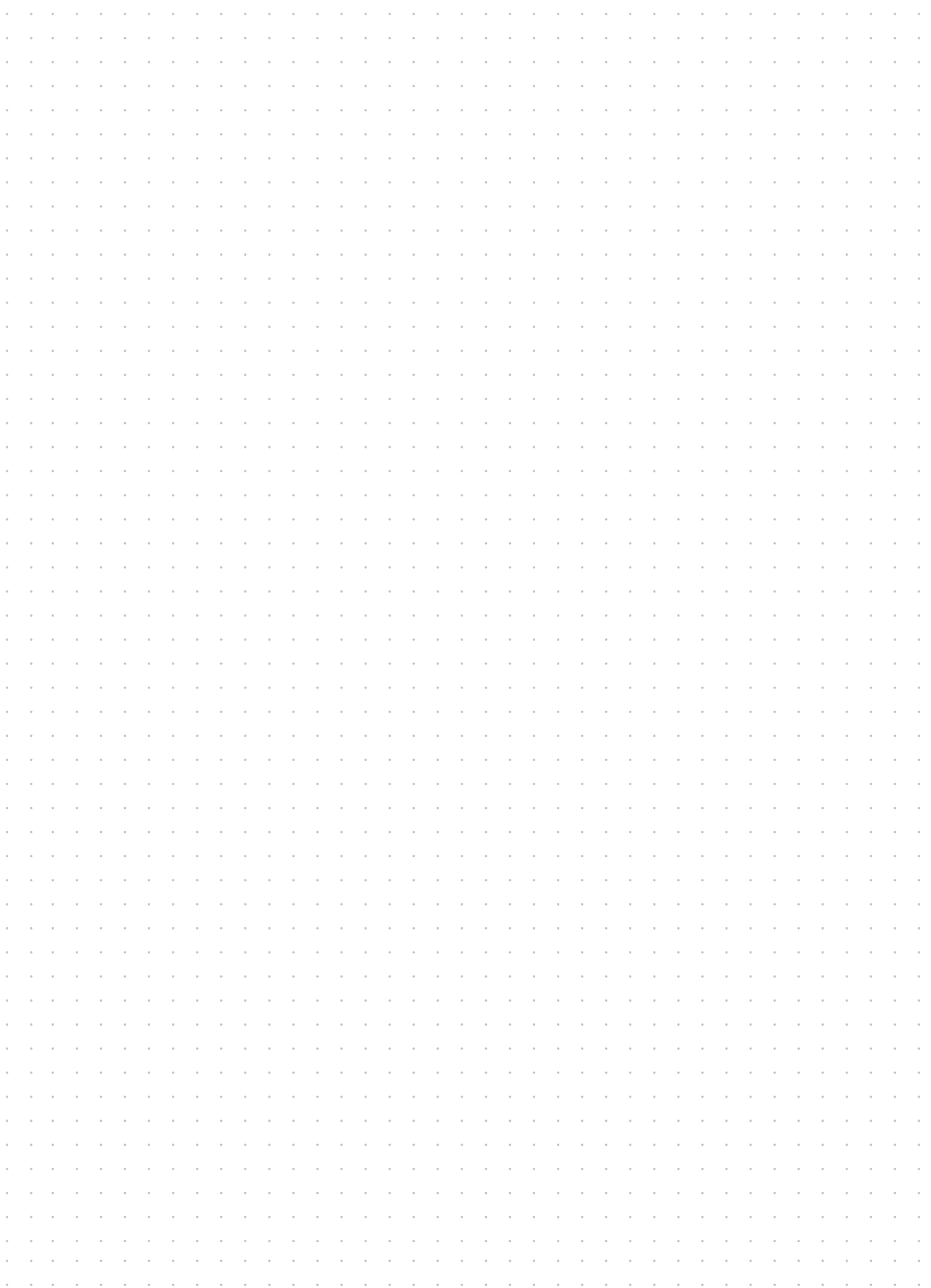

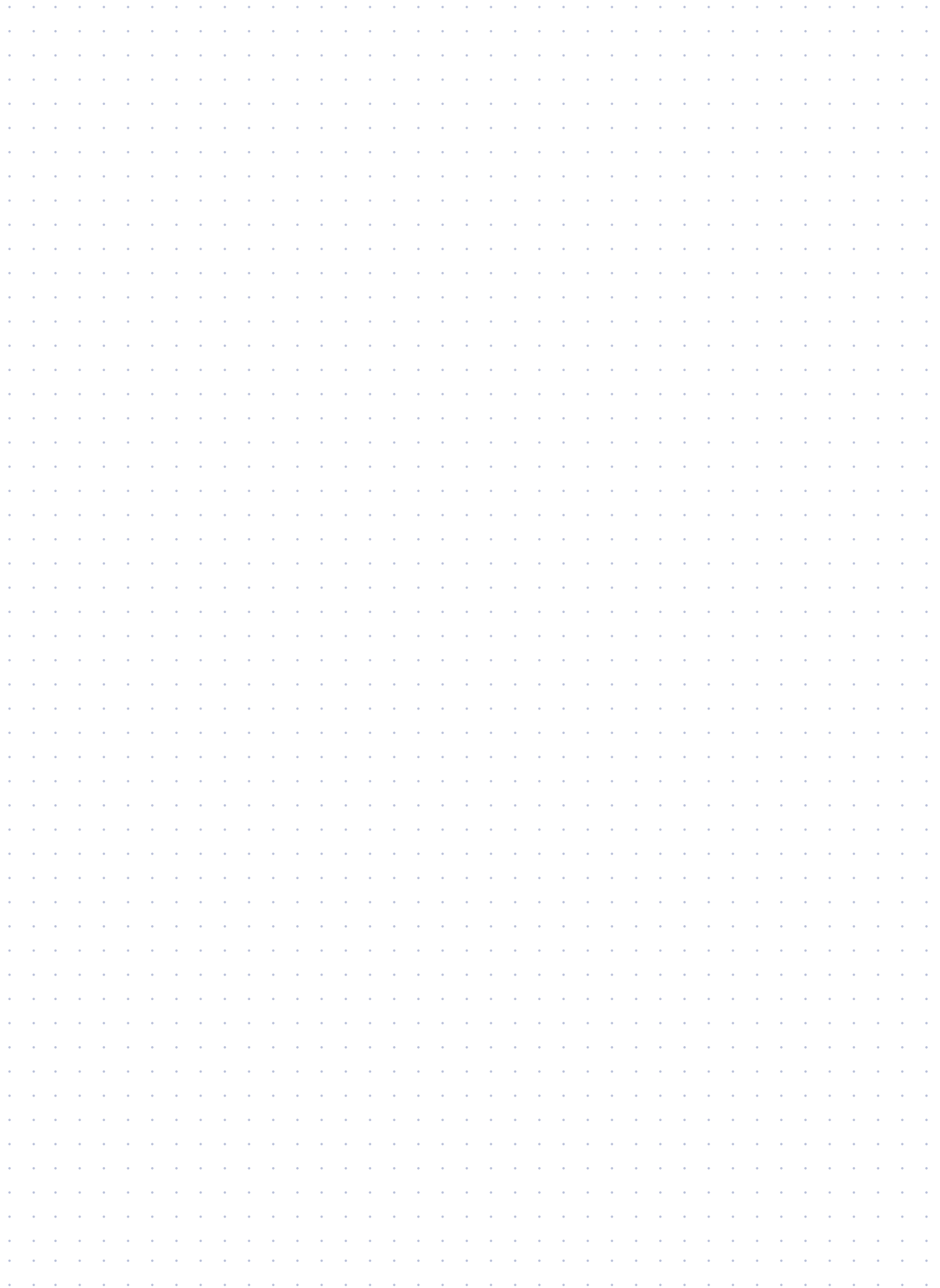

Scope of delivery and services

Catalog no.

1 Open conductor systems	
Open conductor systems	1a
2 Insulated conductor systems	
U10	2a
FABA 100	2b
U15, U25, U35	2c
U20, U30, U40	2d
3 Compact conductor systems	
VKS 10	3a
VKS - VKL	3b
VMT	3c
4 Enclosed conductor systems	
KBSL - KSL	4a
KBH	4b
MKH	4c
LSV - LSVG	4d
5 Contactless power supply	
Contactless power supply (CPS®)	5a
6 Data transmission	
VAHLE Powercom®	6a
Slotted Microwave Guide (SMG)	6b
7 Positioning systems	
VAHLE APOS®	7a
VAHLE APOS® Optic	7b
8 Festoon systems and cables	
Festoon systems for □-tracks	8a
Festoon systems for flatform cables on I-tracks	8b
Festoon systems for round cables on I-tracks	8c
Festoon systems for ◇-tracks	8d
Cables	8e
9 Reels	
Spring-operated cable reels	9a
Motor-powered cable reels	9b
10 Other	
Battery charging systems	10a
Heavy enclosed conductor systems	10b
Tender	10c
Contact wire	10d
11 Automotive Handling	
Control systems	11a
BOK	11b
Assemblies / Commissioning	
Spare parts / Maintenance service	



DQS certified in accordance with DIN EN ISO 9001:2008
OHSAS 18001 (Reg.No. 003140 QM OH)

